

Uniclass L384:N3243+N372
CI/SfB (22.3) X (K2)+(P2)

system 8000 DG technical guide

contents

typical module elevations and section views

glass joint details

component details

head details

wall abutment details

base details

door frame details (glass doors)

door frame details (timber doors)

drywall details

other system integration details

door frame and glazing infill options

Version 2: August 2012

typical module elevations and section views

Drawing description

Drawing number

105mm Double Glazed Typical Module Elevations and Section Views.....PS/8300/0001

system 8000 DG deflection view

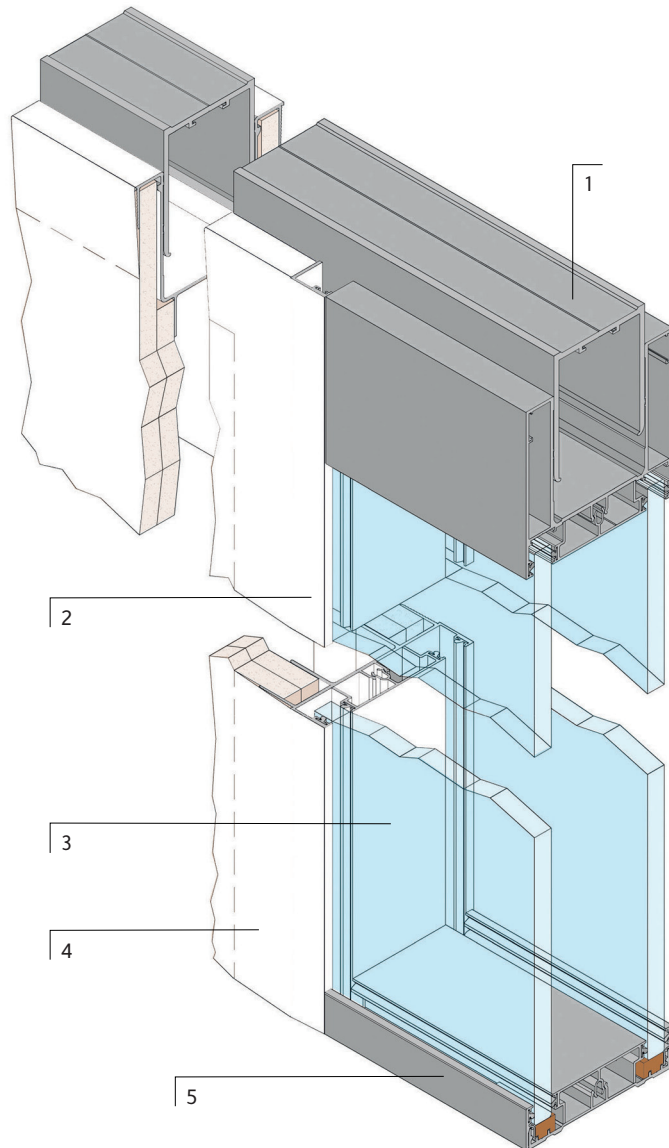

- 1) Two-part Double Glazed deflection head channel with $\pm 25\text{mm}$ deflection to suit 10 and 22mm glass
- 2) Glass and drywall adaptor post
- 3) Glass
- 4) Drywall / SAS Drywall+
- 5) Base track for Double Glazed to suit 10 and 22mm glass

glass joint details

Drawing description

Drawing number

105mm Double Glazed Glass JointsPS/8300/0002

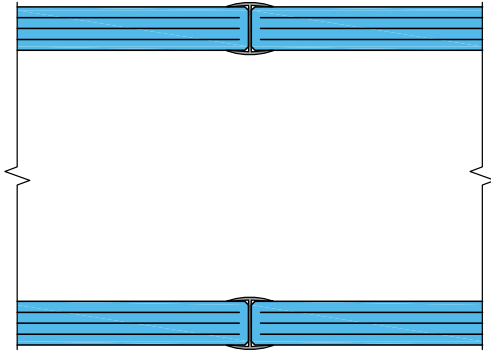

H-JOINT

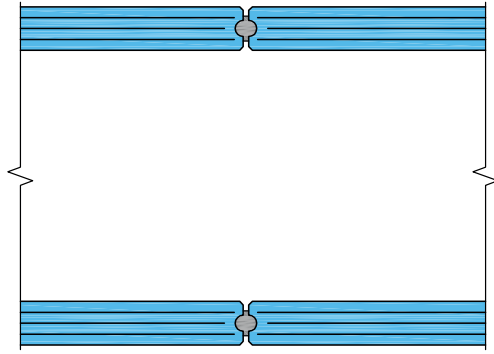

C-JOINT

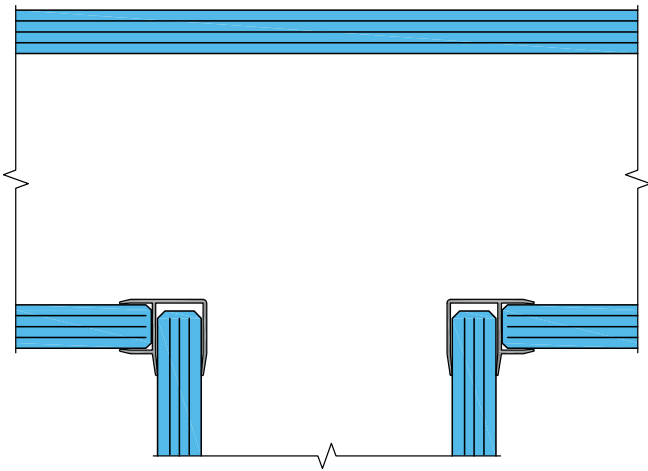

THREE WAY H-JOINT

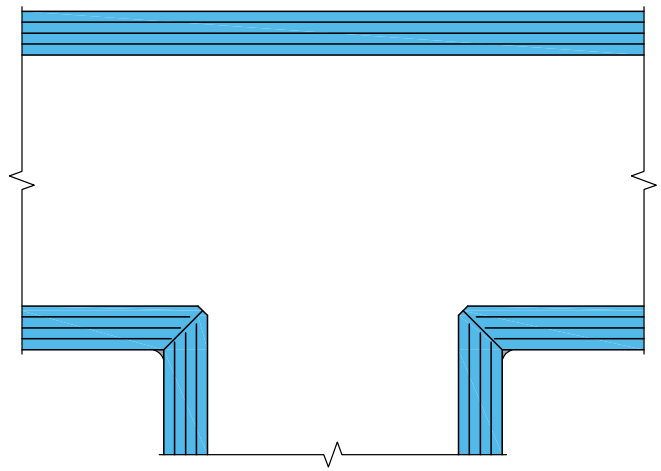

THREE WAY MINIMAL SILICONE BEAD

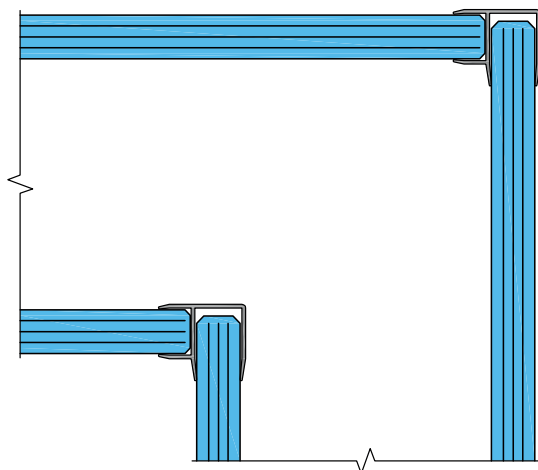

90° H-JOINT

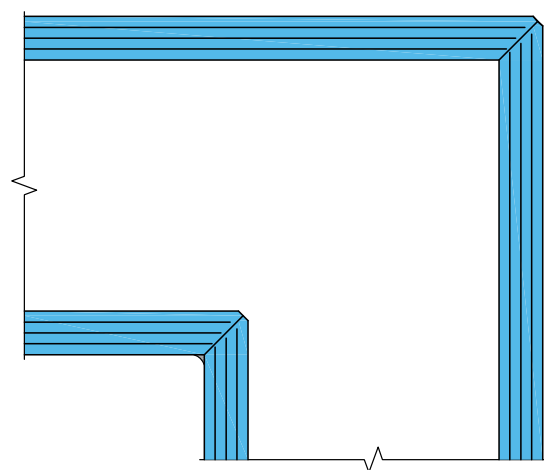

90° MINIMAL SILICONE JOINT



SAS International
31 Suttons Business Park,
London Road, Reading,
Berkshire, RG6 1AZ
Tel: 0118 929 0900
Fax: 0118 929 0908
Technical Helpline:
0118 929 0999
www.sasint.co.uk

SYSTEM 8000

105mm DOUBLE GLAZED
GLASS JOINTS

SCALE @ A4
1:2
DRG NO
PS/8300/0002
ISSUED
INFORMATION

DATE
01/03/2012

DRAWN BY
TC
REV
00
CHECKED
KYE

component details

head track details





base track details

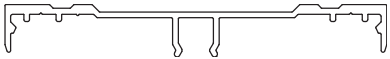

infill section details

door frame details

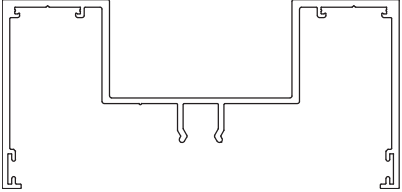
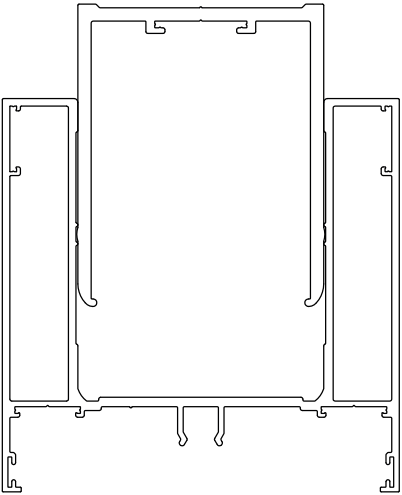
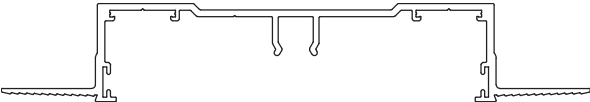
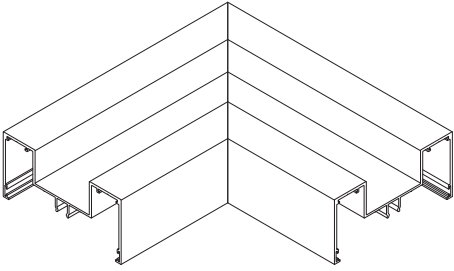
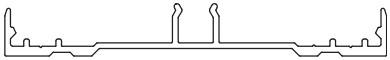
drywall integration details

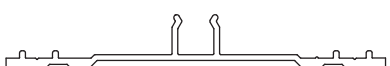
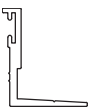

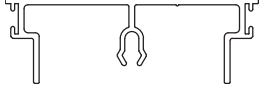
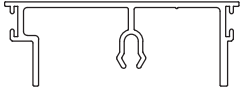
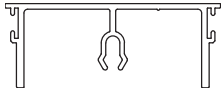
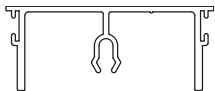
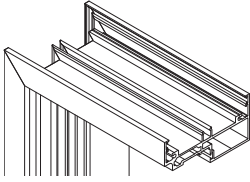
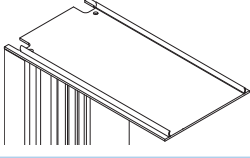
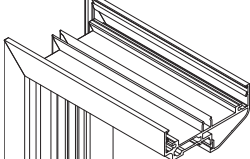
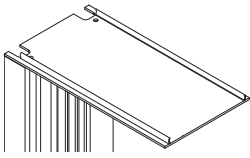
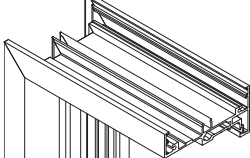
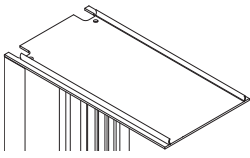
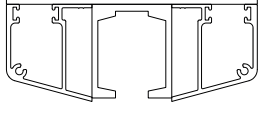



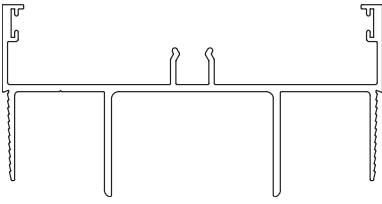
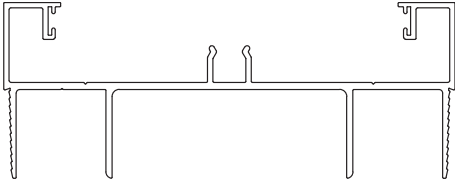
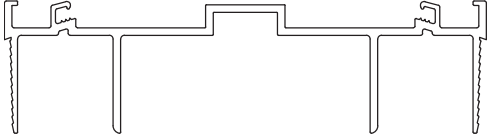
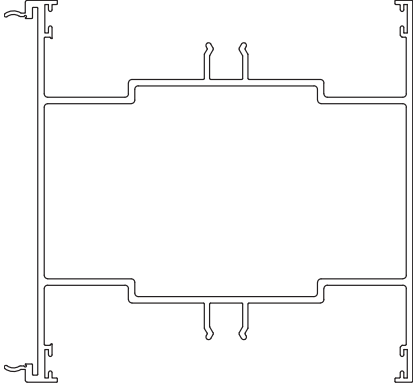
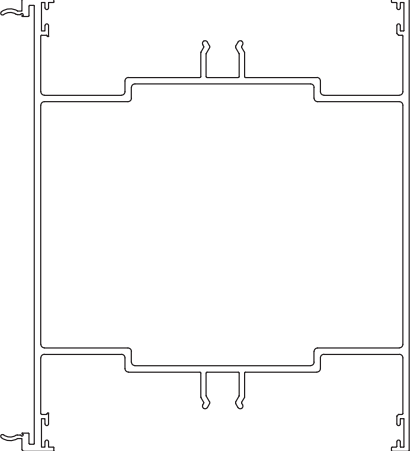

ancillaries



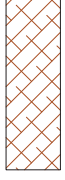
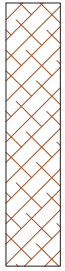
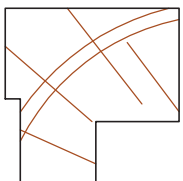
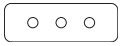
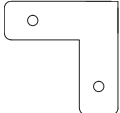
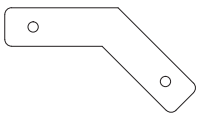

Profile	Product Ref / Description	Item No.
SAS System 8000 DG		
Head Track and Wall Abutment Details		
	105mm Double Glazing Chair (10–12mm Glass)	FG8300
	Glazing Bead	FG8001
	50mm ±15mm Deflection Head Track (10–12mm Glass)	FG8301
	±25mm Deflection Head Inner Channel (10–22mm Glass)	DW1004
	±25mm Deflection Head Outer Channel (10–22mm Glass)	FG8306
	105mm Double Glazed Reveal Channel (10–22mm Glass)	FG8313
	A range of factory fabricated head tracks is available in 90°, 135°, 3 way junctions and bespoke angles. Please contact our technical department for further details.	Various
Base Track Details		
	105mm Double Glazing Chair (10–22mm Glass)	FG8300
	Glazing Bead	FG8001
	Fabricated 105mm Double Glazing Chair (10–22mm Glass) for use with floor angles for varying floor applications.	FG8300M
	Floor Angle	FG8112

Profile	Product Ref / Description	Item No.
SAS System 8000 DG		
Infill Section Details		
	67mm Infill (for 10–12mm and 10–12mm Glass)	FG8302
	62mm Infill (for 10–12mm and 15–17mm Glass)	FG8303
	57mm Infill (for 15–17mm and 15–17mm Glass)	FG8304
	55mm Infill (for 15–17mm and 19–22mm Glass)	FG8305
Door Frame Details		
	Square Door Frame	FG8307
	Double Glazed Slimline Door Frame with Reduced Head	FG8307R
	Chamfered Door Frame	FG8308
	Chamfered Slimline Door Frame with Reduced Head	FG8308R
	Door Frame (12mm Door Stop)	FG8309
	Door Frame (12mm Door Stop) with Reduced Head	FG8309R
	Eclipse Sliding Pocket Door Frame	–
	Flat Clip-in Section	FG8311
	Single Glazed Clip-in Adaptor	FG8312

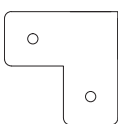
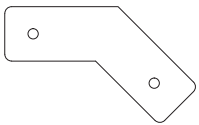
Profile	Product Ref / Description	Item No.
SAS System 8000 105mm DG		
Drywall Integration Details		
	105mm Double Glazed Adaptor for 100mm Drywall	FG8314
	105mm Double Glazed Adaptor for 120mm Drywall	FG8315
	120mm Clip-in Dry Wall Section	FG8006
	105mm Double Glazed Two Way Adaptor for 100mm Drywall	FG8316
	105mm Double Glazed Two Way Adaptor for 120mm Drywall	FG8317

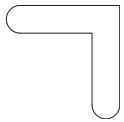
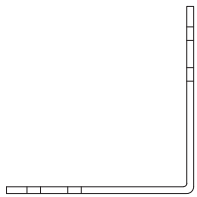
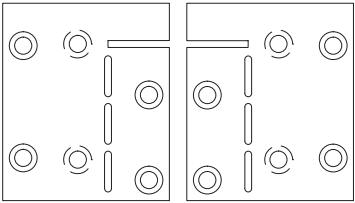
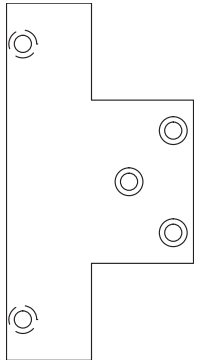
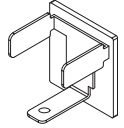
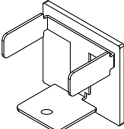
For a range of available milled options please contact our technical department.

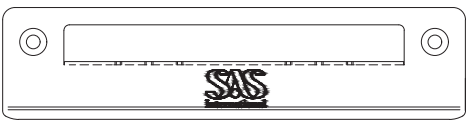
Profile	Product Ref / Description	Item No.
SAS System 8000 Ancillaries		
	Glazing Channel Infill	FG8114
	Glass Seal	112217
	Glass Door Flipper Seal	116117
	Flipper Seal	32037
	27x3mm Plywood Door Frame Infill	116119
	Timber Packer	11637
	38x12mm Timber Door Frame Fixing Packer	FG8007
	58x12mm Timber Door Frame Fixing Packer	FG8008
	Timber Infill – use with FG8117	110440
	50 x 17mm Flat Splice Plate	110667
	50 x 17mm 90° Corner Splice Plate	110657
	50 x 17mm 135° Corner Splice Plate	110668
	50 x 24mm Flat Splice Plate	110665
	50 x 24mm 90° Corner Cleat	110669
	50 x 24mm 135° Corner Splice Plate	110655

Profile	Product Ref / Description	Item No.
SAS System 8000 Ancillaries		
	50 x 50mm 90° Corner Cleat	35768
	Door Frame Ceiling Fixing Cleat	35772
	Slimline Door Frame Fixing Plate (right hand)	116113
	Slimline Door Frame Fixing Plate (left hand)	116111
	Double Glazed Door Frame Fixing Plate	116114
	Steel End Cap	FG8009
	Steel End Cap	FG8010
	Glass Door Strike Plate	116294
	Glass Door Shallow Back Box	118868
	Strike Plate	116120
	Shallow Back Box	116121
	Deep Back Box	116929

head details

Drawing description	Drawing number
Two Part Head Detail (10/12mm Glass)	PS/8300/1000
50mm Head Detail (10/12mm Glass).....	PS/8300/1001
Deflection Head Detail (10/12mm Glass).....	PS/8300/1002

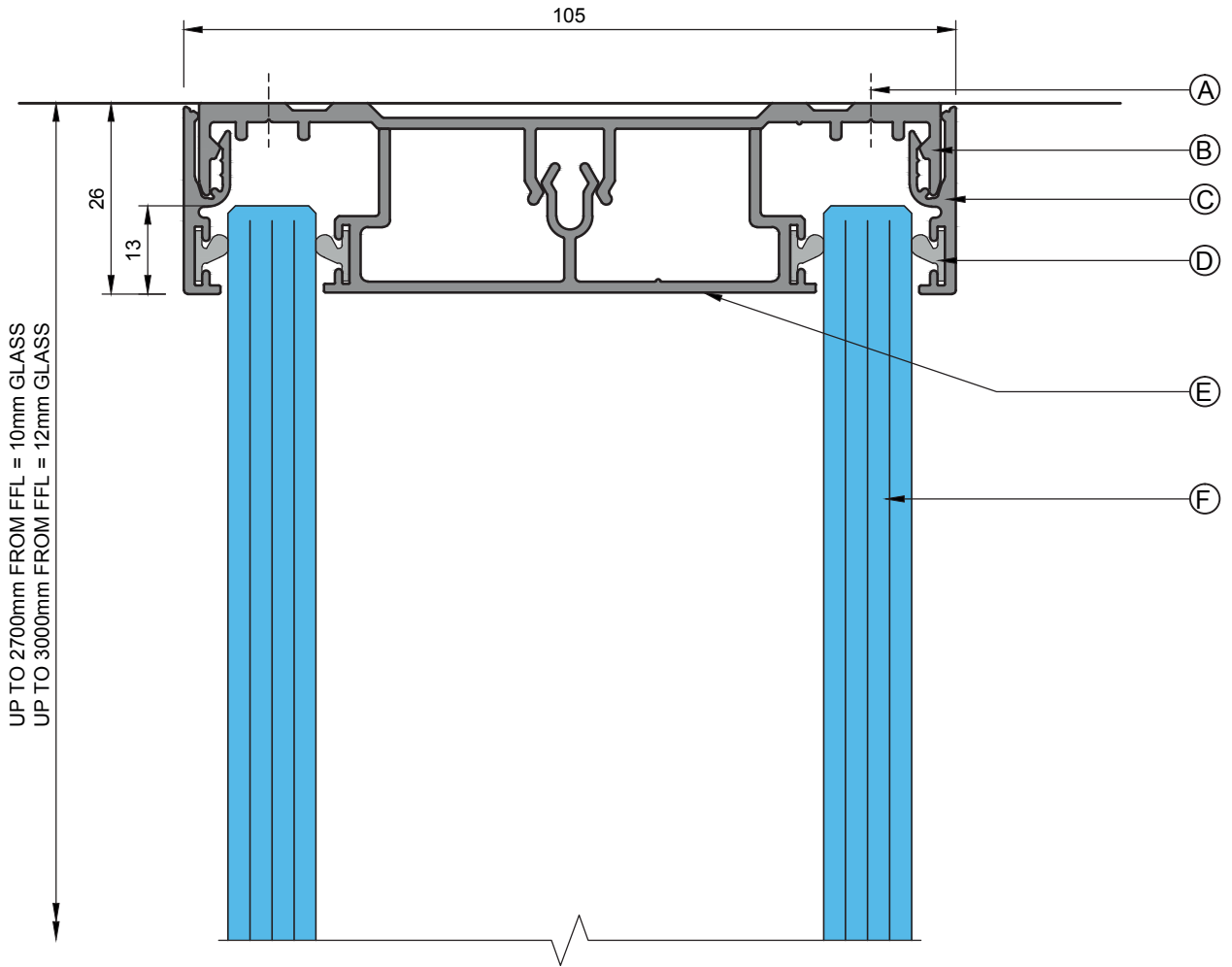

- A: SUITABLE FIXINGS
 B: FG8300 DOUBLE GLAZED TRACK
 C: FG8001 GLAZING BEAD
 D: 112217 Q-LON SEAL
 E: FG8302 DOUBLE GLAZED 67mm INFILL
 (FOR OTHER GLAZING INFILL OPTIONS PLEASE REFER TO DRAWING PS/8300/0901)
 F: 10/12mm GLASS (NOMINAL GLASS THICKNESS NOTED)

NON FIRE RATED
 SEE FIRE RATED SERIES
 OF DRAWINGS



SAS International
 31 Suttons Business Park,
 London Road, Reading,
 Berkshire, RG6 1AZ
 Tel: 0118 929 0900
 Fax: 0118 929 0908
 Technical Helpline:
 0118 929 0998
 www.sasint.co.uk

SYSTEM 8000

105mm DOUBLE GLAZED
 TWO PART HEAD DETAIL

SCALE @ A4
 1:1
 DRG NO
 PS/8300/1000
 ISSUED
 INFORMATION

DATE
 01/03/2012

DRAWN BY
 TC
 REV
 00
 CHECKED
 KYE

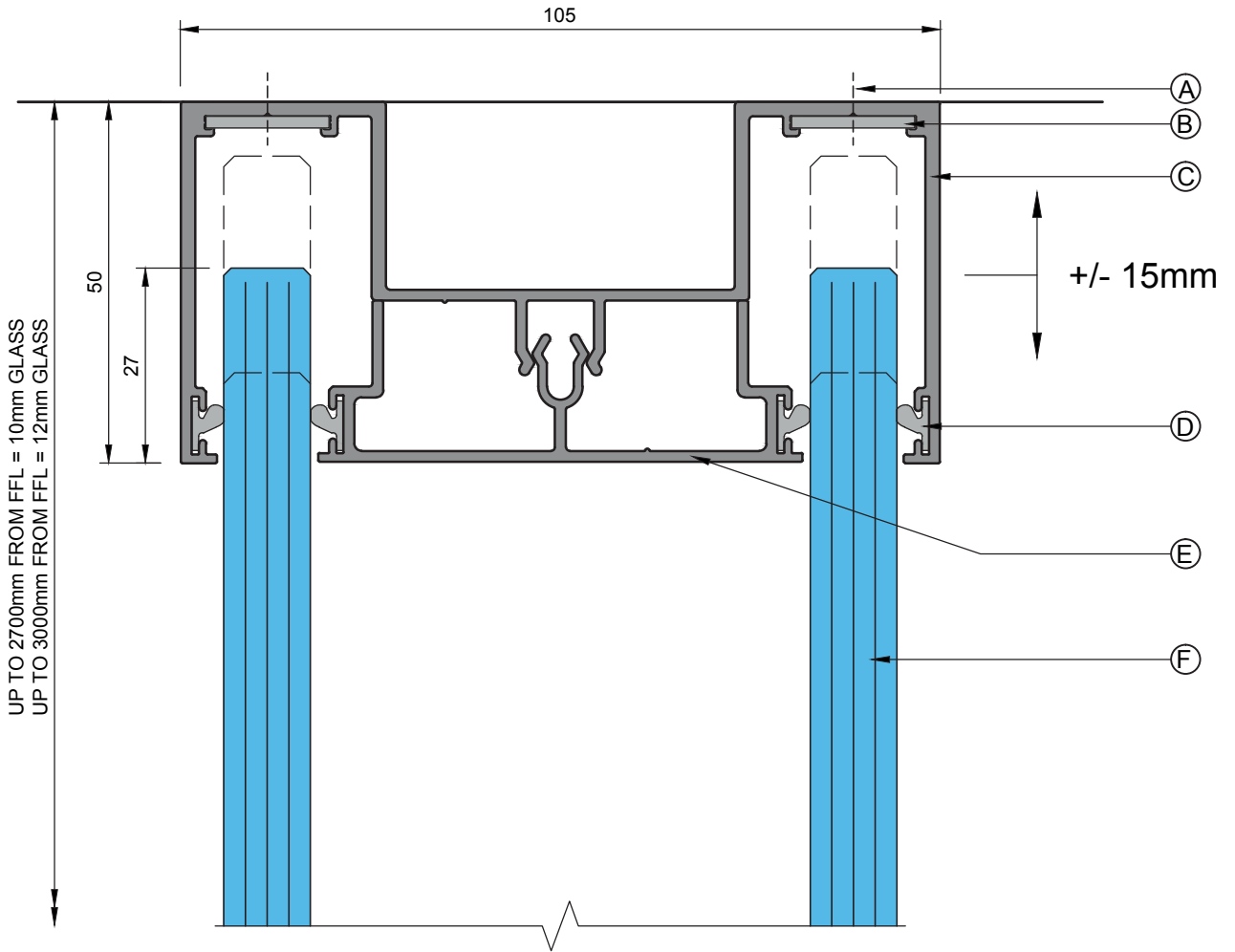

UP TO 2700mm FROM FFL = 10mm GLASS
 UP TO 3000mm FROM FFL = 12mm GLASS

- A: SUITABLE FIXINGS
- B: 50 x 17mm SPLICE PLATE (STRAIGHT, 90° AND 135° AVAILABLE)
- C: FG8301 50mm DOUBLE GLAZED TRACK
- D: 112217 Q-LON SEAL
- E: FG8302 DOUBLE GLAZED 67mm INFILL
 (FOR OTHER GLAZING INFILL OPTIONS PLEASE REFER TO DRAWING PS/8300/0901)
- F: 10/12mm GLASS (NOMINAL GLASS THICKNESS NOTED)

NON FIRE RATED
 SEE FIRE RATED SERIES
 OF DRAWINGS



SAS International
 31 Suttons Business Park,
 London Road, Reading,
 Berkshire, RG6 1AZ
 Tel: 0118 929 0900
 Fax: 0118 929 0908
 Technical Helpline:
 0118 929 0998
 www.sasint.co.uk

SYSTEM 8000

105mm DOUBLE GLAZED
 50mm HEAD DETAIL

SCALE @ A4
 1:1
 DRG NO
 PS/8300/1001
 ISSUED
 INFORMATION

DATE
 01/03/2012

DRAWN BY
 TC
 REV
 00
 CHECKED
 KYE

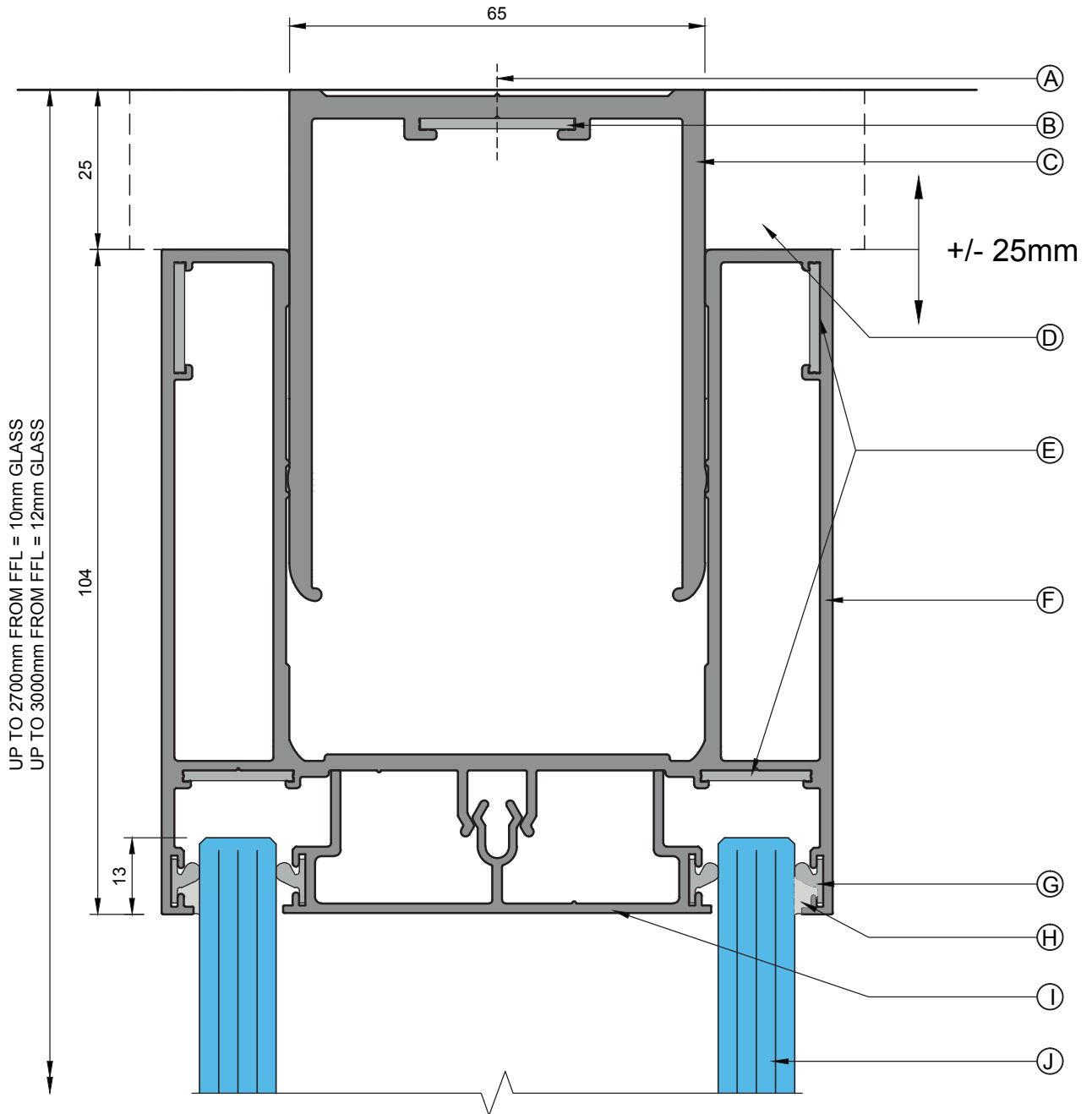

- A: SUITABLE FIXINGS
 B: 50 x 24mm SPLICE PLATE (STRAIGHT, 90° AND 135° AVAILABLE)
 C: DW1004 DOUBLE GLAZED INNER DEFLECTION HEAD
 D: 119476 25 x 25mm SETTING BLOCK
 E: 50 x 17mm SPLICE PLATE (STRAIGHT, 90° AND 135° AVAILABLE)
 F: FG8306 DOUBLE GLAZED OUTER DEFLECTION HEAD
 G: 112217 Q-LON SEAL
 H: MINIMAL SILICONE JOINT
 I: FG8302 DOUBLE GLAZED 67mm INFILL
 (FOR OTHER GLAZING INFILLS PLEASE REFER TO DRAWING PS/8300/0901)
 J: 10/12mm GLASS (NOMINAL GLASS THICKNESS NOTED)

NON FIRE RATED
 SEE FIRE RATED SERIES
 OF DRAWINGS



SAS International
 31 Suttons Business Park,
 London Road, Reading,
 Berkshire, RG6 1AZ
 Tel: 0118 929 0900
 Fax: 0118 929 0908
 Technical Helpline:
 0118 929 0998
 www.sasint.co.uk

SYSTEM 8000

105mm DOUBLE GLAZED
 DEFLECTION HEAD DETAIL

SCALE @ A4
 1:1
 DRG NO
 PS/8300/1002
 ISSUED
 INFORMATION

DATE
 01/03/2012

DRAWN BY
 TC
 REV
 00
 CHECKED
 KYE

wall abutment details

Drawing description	Drawing number
Two Part Wall Abutment Detail (10/12mm Glass).....	PS/8300/2000
50mm Wall Abutment Detail (10/12mm Glass).....	PS/8300/2001
Wall Abutment Movement Detail (10/12mm Glass).....	PS/8300/2002

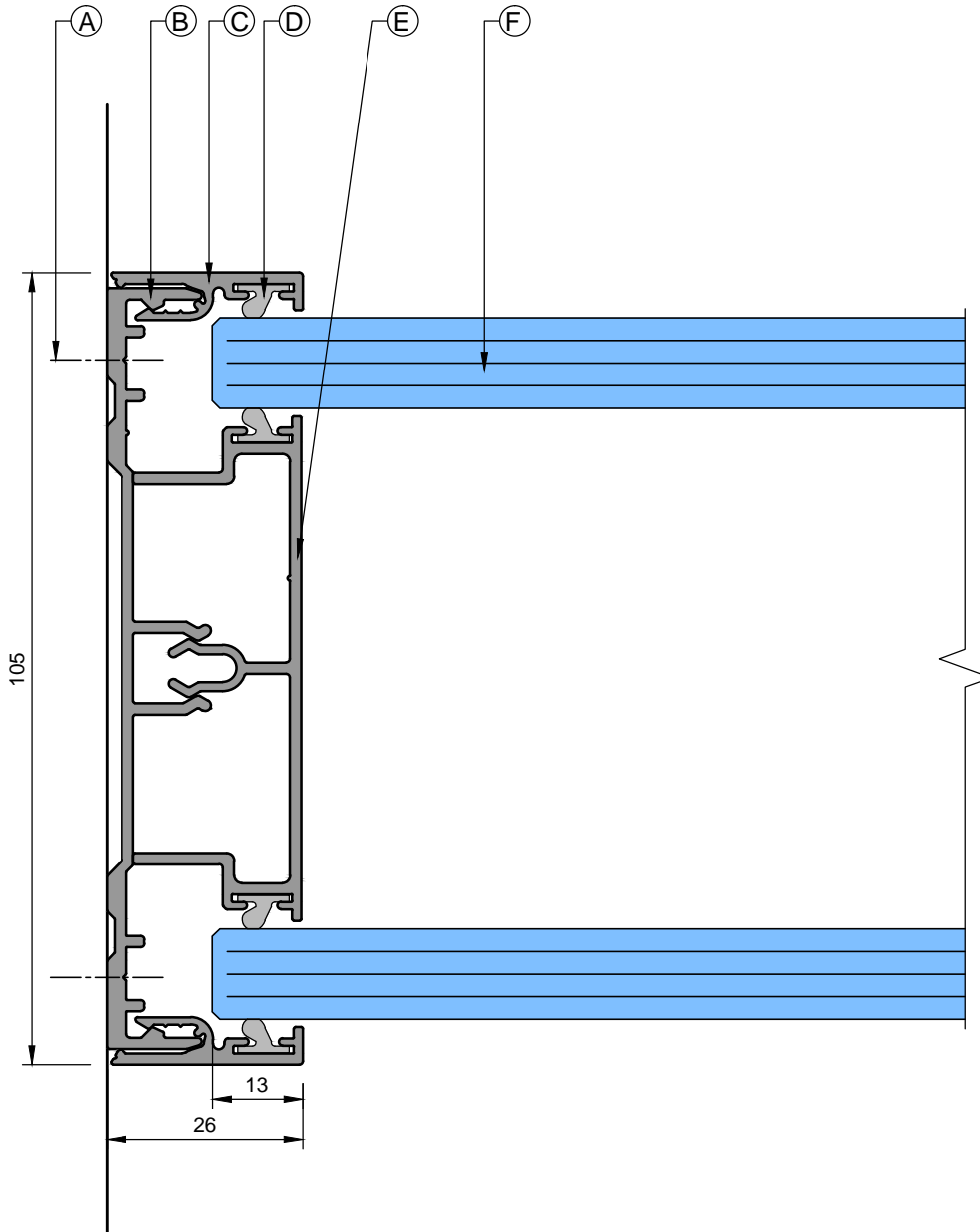

- A: SUITABLE FIXINGS
- B: FG300 DOUBLE GLAZING TRACK
- C: FG8001 GLAZING BEAD
- D: 112217 Q-LON SEAL
- E: FG8302 DOUBLE GLAZED 67mm INFILL
(FOR OTHER GLAZING INFILL OPTIONS PLEASE REFER TO DRAWING PS/8300/0901)
- F: 10/12mm GLASS (NOMINAL GLASS THICKNESS NOTED)

NON FIRE RATED

SEE FIRE RATED SERIES OF DRAWINGS



SAS International
 31 Suttons Business Park,
 London Road, Reading,
 Berkshire, RG6 1AZ
 Tel: 0118 929 0900
 Fax: 0118 929 0908
 Technical Helpline:
 0118 929 0998
 www.sasint.co.uk

SYSTEM 8000

105mm DOUBLE GLAZED
 TWO PART WALL ABUTMENT DETAIL

SCALE @ A4
 1:1
 DRG NO
 PS/8300/2000
 ISSUED
 INFORMATION

DATE
 01/03/2012

DRAWN BY
 TC
 REV
 01
 CHECKED
 KYE

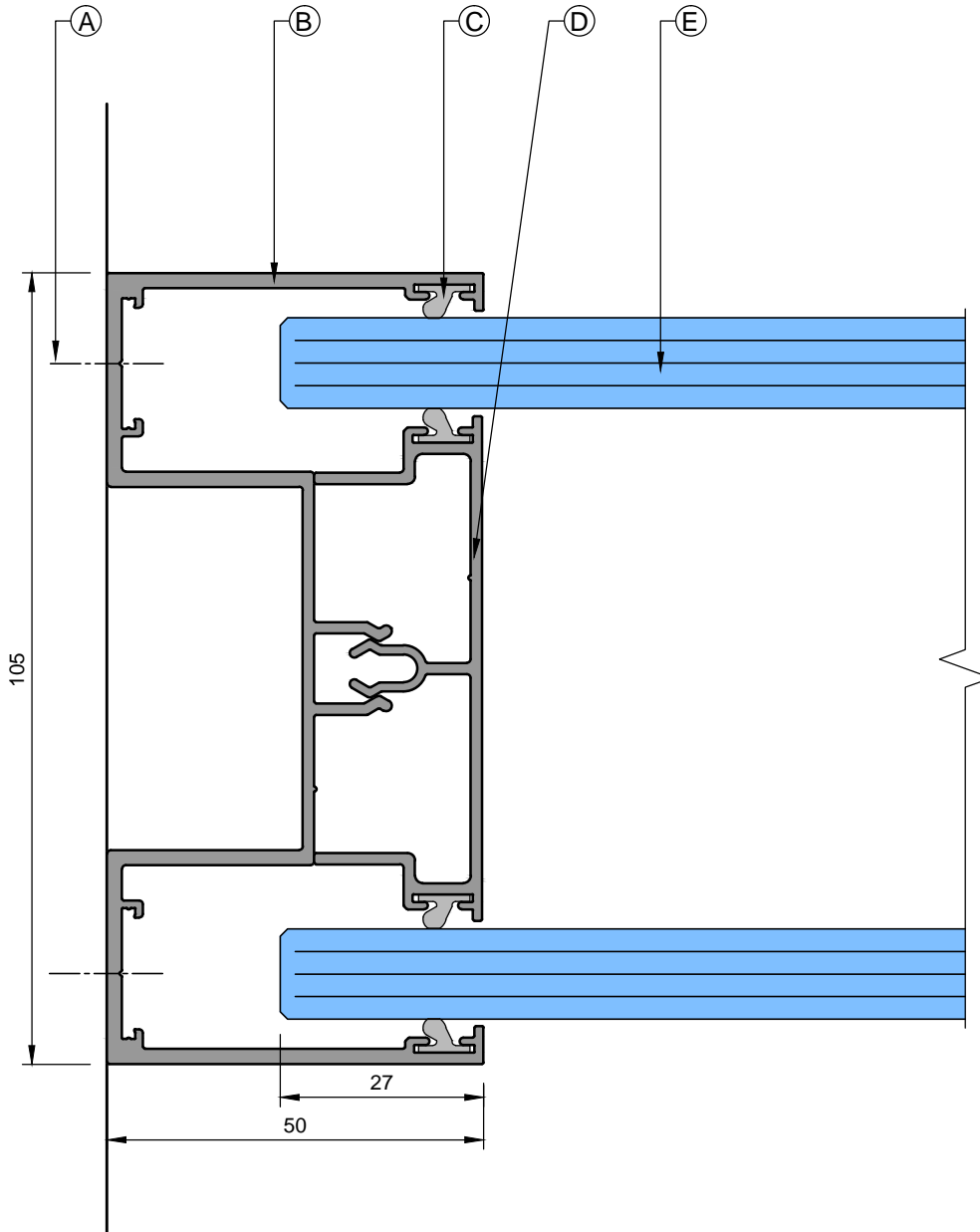

- A: SUITABLE FIXINGS
- B: FG301 50mm DOUBLE GLAZING TRACK
- C: 112217 Q-LON SEAL
- D: FG8302 DOUBLE GLAZED 67mm INFILL
(FOR OTHER GLAZING INFILL OPTIONS PLEASE REFER TO DRAWING PS/8300/0901)
- E: 10/12mm GLASS (NOMINAL GLASS THICKNESS NOTED)

NON FIRE RATED

SEE FIRE RATED SERIES OF DRAWINGS



SAS International
 31 Suttons Business Park,
 London Road, Reading,
 Berkshire, RG6 1AZ
 Tel: 0118 929 0900
 Fax: 0118 929 0908
 Technical Helpline:
 0118 929 0998
 www.sasint.co.uk

SYSTEM 8000

105mm DOUBLE GLAZED
 50mm WALL ABUTMENT DETAIL

SCALE @ A4
 1:1
 DRG NO
 PS/8300/2001
 ISSUED
 INFORMATION

DATE
 01/03/2012

DRAWN BY
 TC
 REV
 01
 CHECKED
 KYE

SAS International claims proprietary rights in the information disclosed hereon. This drawing is furnished in confidence on the express understanding that neither it nor any reproduction thereof will be disclosed to others or used for the purpose of manufacture or procurement of the article or part shown hereon without the express consent in writing of SAS International. It should be understood that any article or part either made in accordance with the attached drawing or copied from an article or part made in accordance with said drawing, without the express permission in writing of SAS International, will be an infringement of the Copyright which subsists in said drawing and therefore actionable by law.
 © 2010 SAS International

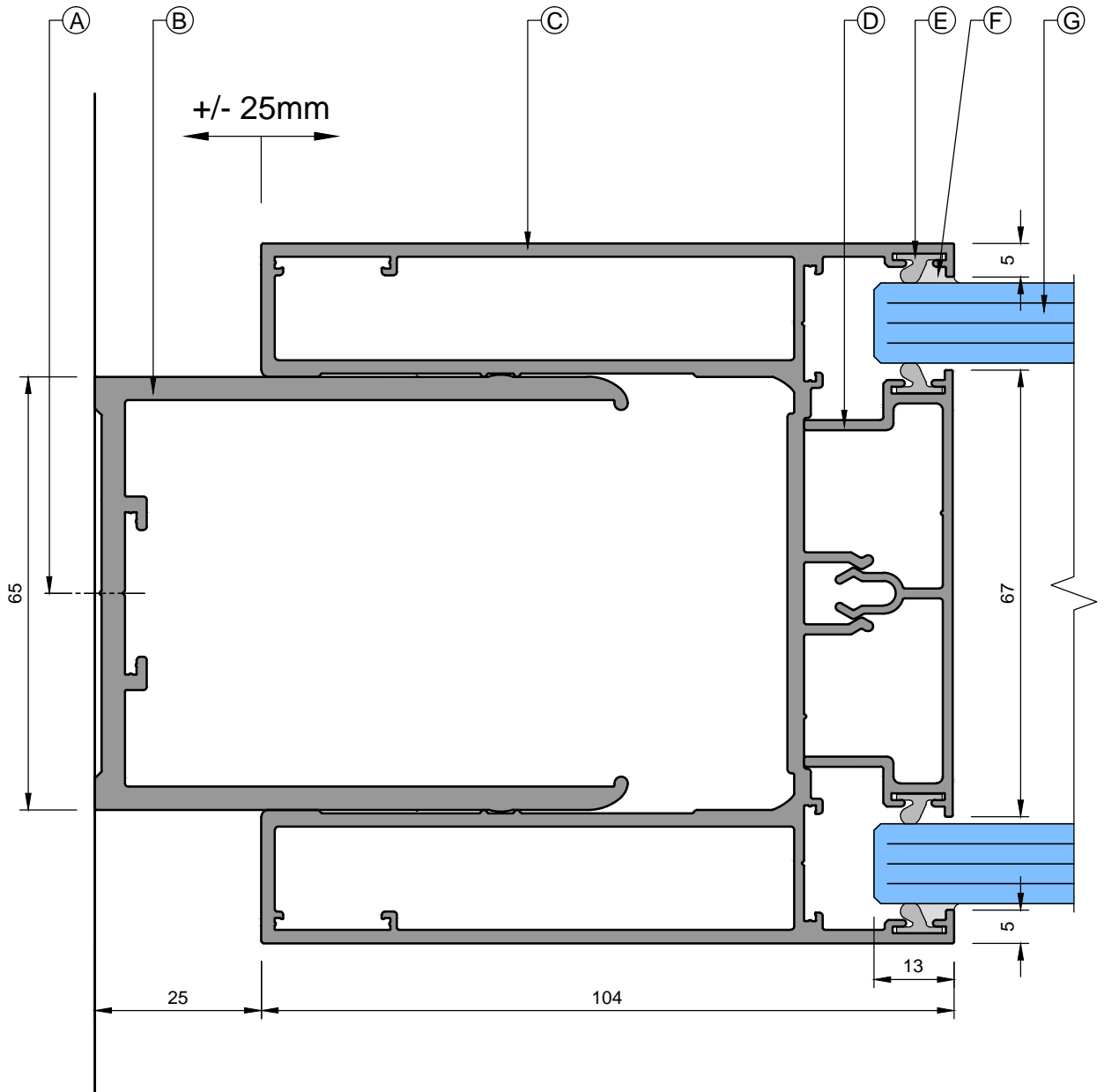

- A: SUITABLE FIXINGS
- B: DW1004 DOUBLE GLAZED INNER DEFLECTION
- C: FG8306 DOUBLE GLAZED OUTER DEFLECTION
- D: FG8302 DOUBLE GLAZED 67mm INFILL
(FOR OTHER INFILL OPTIONS PLEASE REFER TO DRAWING PS/8300/0901)
- E: 112217 Q-LON SEAL
- F: MINIMAL SILICONE JOINT
- G: 10/12mm GLASS (NOMINAL GLASS THICKNESS NOTED)

NON FIRE RATED
SEE FIRE RATED SERIES
OF DRAWINGS



SAS International
31 Suttons Business Park,
London Road, Reading,
Berkshire, RG6 1AZ
Tel: 0118 929 0900
Fax: 0118 929 0908
Technical Helpline:
0118 929 0998
www.sasint.co.uk

SYSTEM 8000

105mm DOUBLE GLAZED
WALL ABUTMENT MOVEMENT DETAIL

SCALE @ A4
1:1
DRG NO
PS/8300/2002
ISSUED
INFORMATION

DATE
01/03/2012

DRAWN BY
TC
REV
01
CHECKED
KYE

base details

Drawing description	Drawing number
Two Part Base Detail (10/12mm Glass).....	PS/8300/3000
Floor Angle Base Detail (10/12mm Glass).....	PS/8300/3001

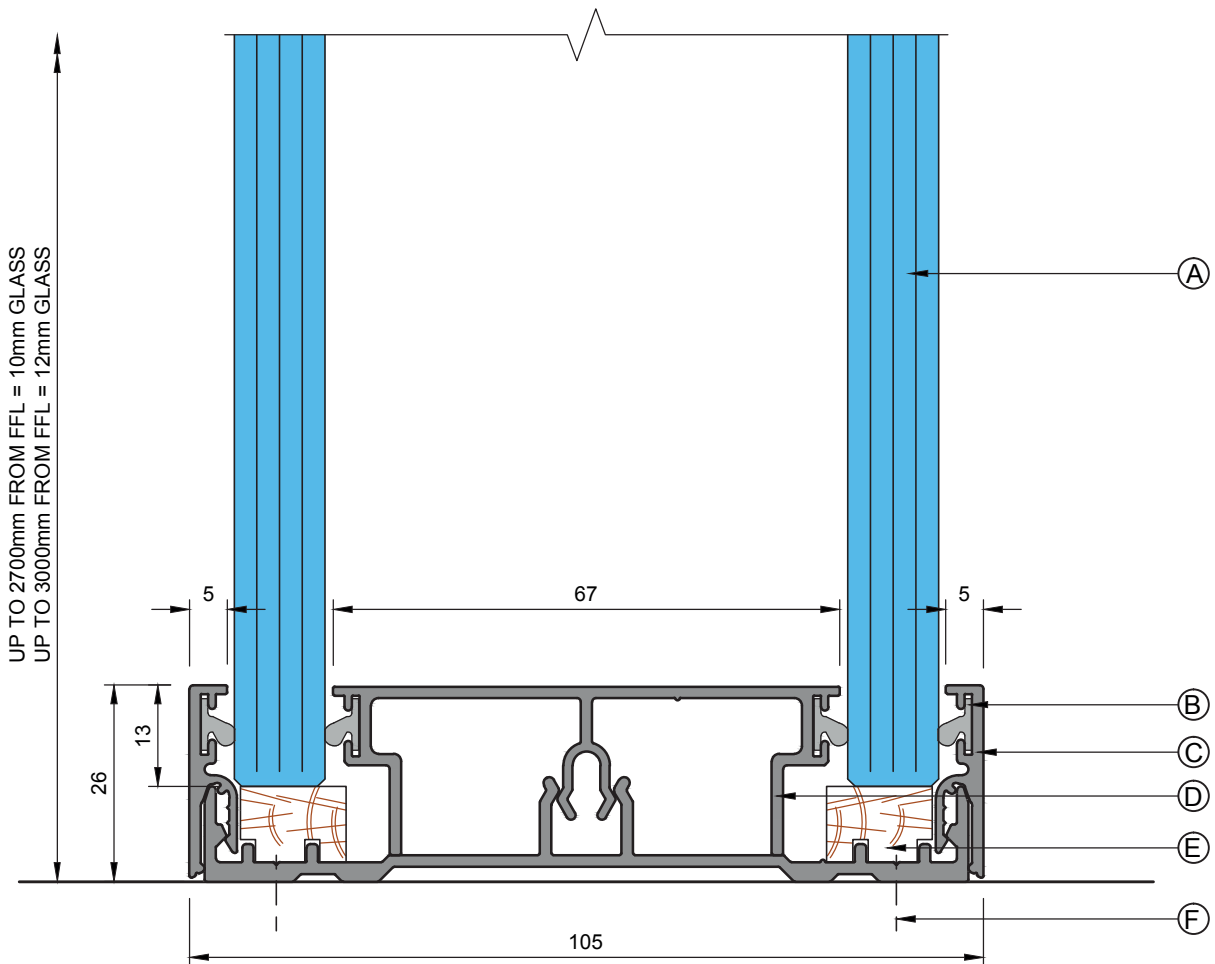

- A: 10/12mm GLASS (NOMINAL GLASS THICKNESS NOTED)
- B: 112217 Q-LON SEAL
- C: FG8001 GLAZING BEAD
- D: FG8302 DOUBLE GLAZING 67mm INFILL
(FOR OTHER INFILL OPTIONS PLEASE REFER TO DRAWING PS/8300/0901)
- E: 111629 14 x 10mm TIMBER GLAZING PACKER
- F: SUITABLE FIXINGS

NON FIRE RATED

SEE FIRE RATED SERIES
OF DRAWINGS



SAS International
31 Suttons Business Park,
London Road, Reading,
Berkshire, RG6 1AZ
Tel: 0118 929 0900
Fax: 0118 929 0908
Technical Helpline:
0118 929 0998
www.sasint.co.uk

SYSTEM 8000

105mm DOUBLE GLAZED
TWO PART BASE DETAIL

SCALE @ A4
1:1
DRG NO
PS/8300/3000
ISSUED
INFORMATION

DATE
01/03/2012

DRAWN BY
TC
REV
00
CHECKED
KYE

UP TO 2700mm FROM FFL = 10mm GLASS
 UP TO 3000mm FROM FFL = 12mm GLASS

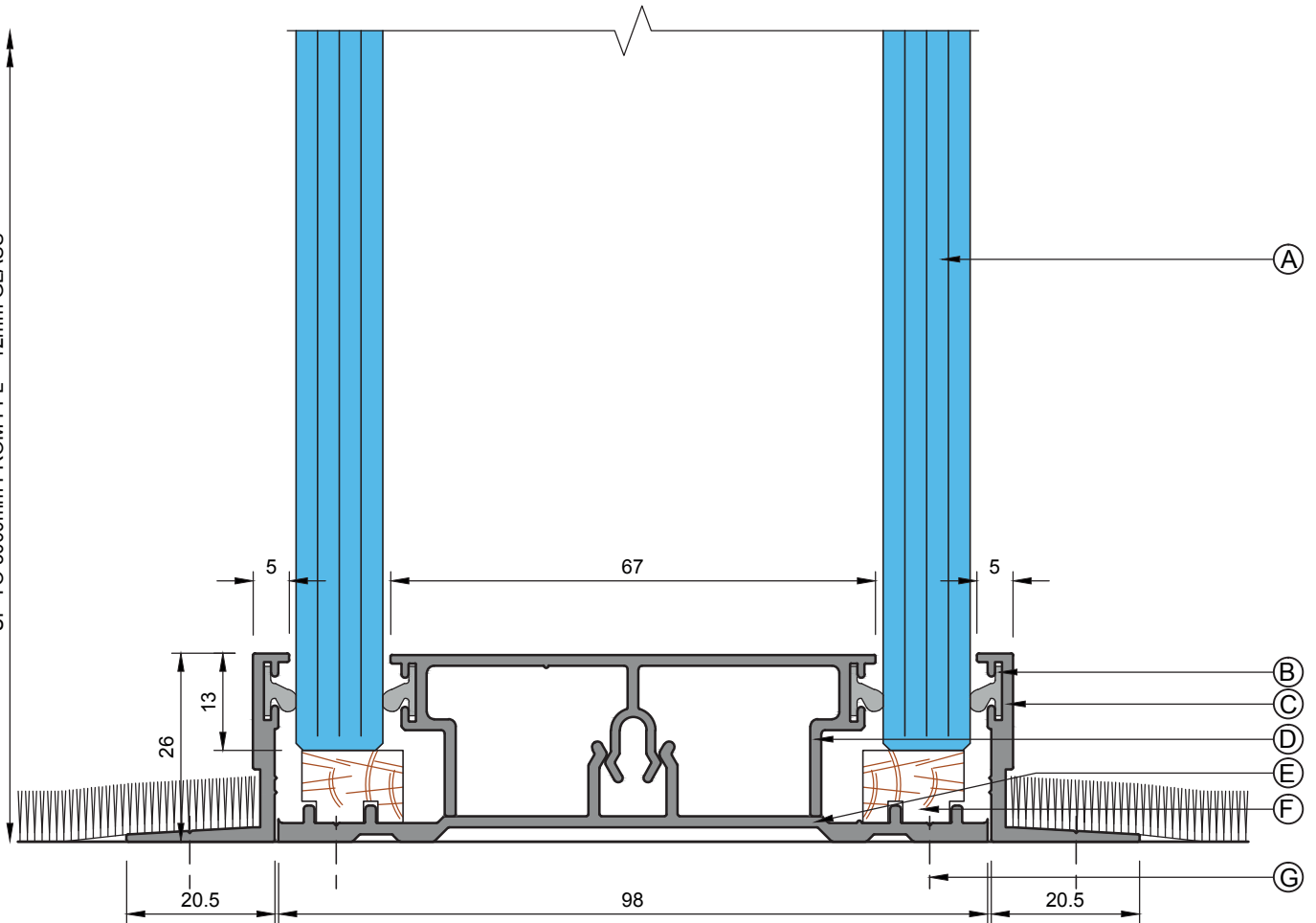

- A: 10/12mm GLASS (NOMINAL GLASS THICKNESS NOTED)
- B: 112217 Q-LON SEAL
- C: FG8112 FLOOR ANGLE
- D: FG8302 DOUBLE GLAZING 67mm INFILL
 (FOR OTHER GLAZING OPTIONS PLEASE REFER TO PS/8300/0901)
- E: FG8300M DOUBLE GLAZING TRACK (MODIFIED)
- F: 111629 14 x 10mm TIMBER GLAZING PACKER
- G: SUITABLE FIXINGS

NON FIRE RATED
 SEE FIRE RATED SERIES
 OF DRAWINGS



SAS International
 31 Suttons Business Park,
 London Road, Reading,
 Berkshire, RG6 1AZ
 Tel: 0118 929 0900
 Fax: 0118 929 0908
 Technical Helpline:
 0118 929 0998
 www.sasint.co.uk

SYSTEM 8000

105mm DOUBLE GLAZED
 TWO PART BASE DETAIL

SCALE @ A4
 1:1
 DRG NO
 PS/8300/3001
 ISSUED
 INFORMATION

DATE
 01/03/2012

DRAWN BY
 TC
 REV
 00
 CHECKED
 KYE

door frame details (glass doors)

Drawing description	Drawing number
Hinged Glass Door Leaf Vertical Section.....	PS/8300/4200
Hinged Glass Door Leaf (GDDS) Vertical Section.....	PS/8300/4201
Door Frame Head Detail.....	PS/8300/4202
Two Part Door Frame Head Detail.....	PS/8300/4203
50mm Door Frame Head Detail.....	PS/8300/4204
Deflection Door Frame Head Detail.....	PS/8300/4205
Two Part Reduced Head Detail.....	PS/8300/4206
50mm Reduced Head Detail.....	PS/8300/4207
Deflection Reduced Head Detail.....	PS/8300/4208
Door Frame With Glass Above (10/12mm Glass).....	PS/8300/4209
Single Hinged Glass Door Leaf Horizontal Section.....	PS/8300/4300
Double Hinged Glass Door Leaf Horizontal Section.....	PS/8300/4301
Door Frame Jamb (10/12mm Glass).....	PS/8300/4302
Door Frame Wall Abutment.....	PS/8300/4303

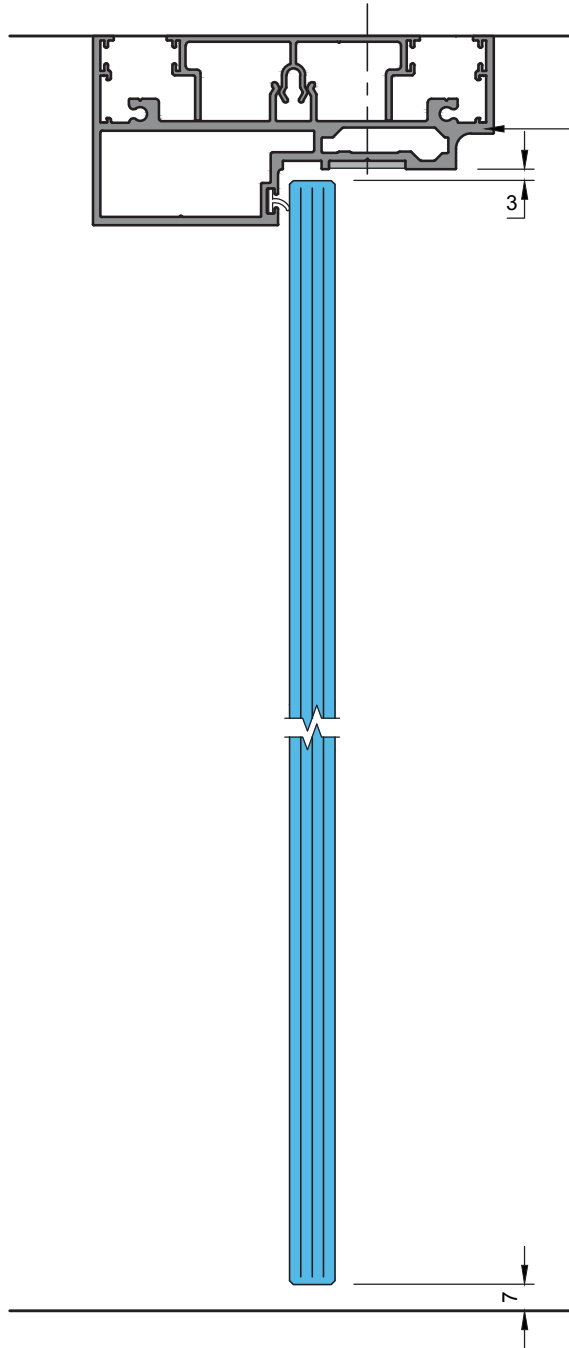

PLEASE REFER TO
SUBSEQUENT
DRAWINGS FOR
HINGED GLASS DOOR
HEAD OPTIONS

NON FIRE RATED
SEE FIRE RATED SERIES
OF DRAWINGS



SAS International
31 Suttons Business Park,
London Road, Reading,
Berkshire, RG6 1AZ
Tel: 0118 929 0900
Fax: 0118 929 0908
Technical Helpline:
0118 929 0998
www.sasint.co.uk

SYSTEM 8000

105mm DOUBLE GLAZED
HINGED GLASS DOOR LEAF

SCALE @ A4
1:2
DRG NO
PS/8300/4200
ISSUED
INFORMATION

DATE
01/03/2012

DRAWN BY
TC
REV
00
CHECKED
KYE

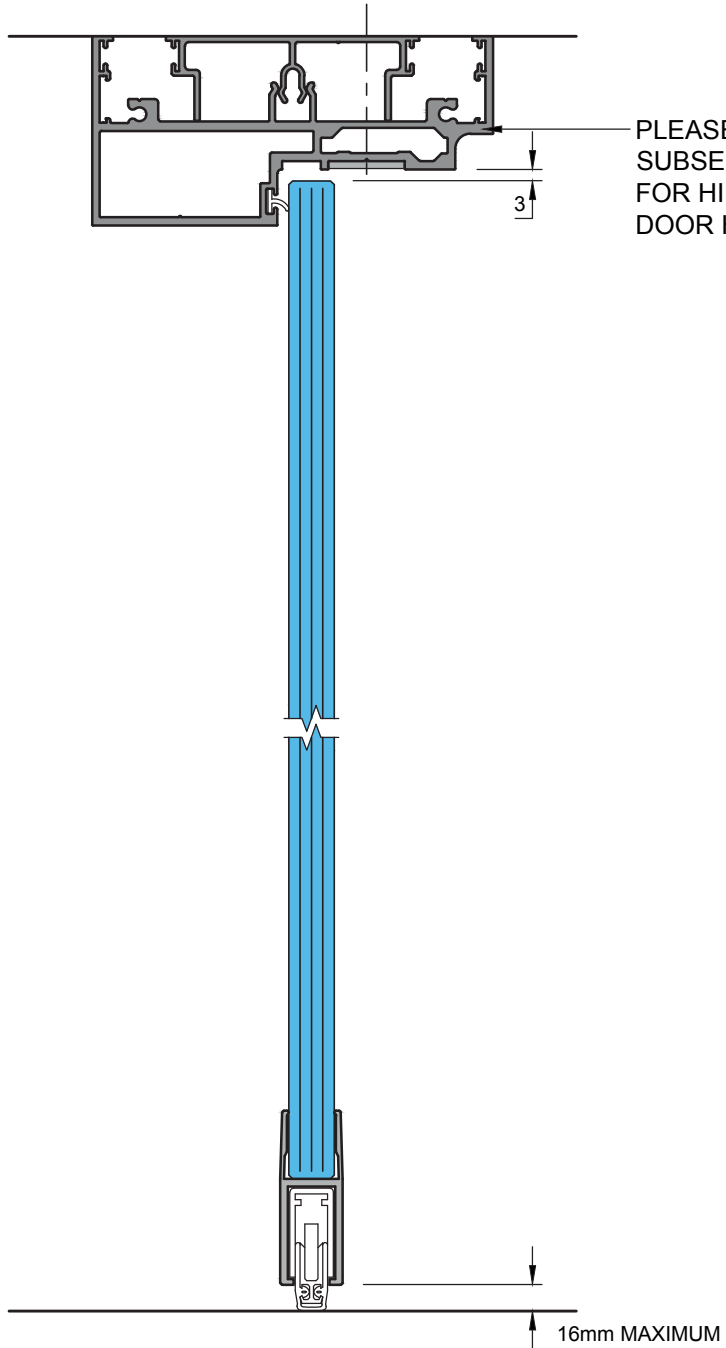

PLEASE REFER TO
SUBSEQUENT DRAWINGS
FOR HINGED GLASS
DOOR HEAD OPTIONS

16mm MAXIMUM

NON FIRE RATED
SEE FIRE RATED SERIES
OF DRAWINGS

32dB



SAS International
31 Suttons Business Park,
London Road, Reading,
Berkshire, RG6 1AZ
Tel: 0118 929 0900
Fax: 0118 929 0908
Technical Helpline:
0118 929 0998
www.sasint.co.uk

SYSTEM 8000

105mm DOUBLE GLAZED
HINGED GLASS DOOR LEAF (GDGS)

SCALE @ A4
1:2
DRG NO
PS/8300/4201
ISSUED
INFORMATION

DATE
01/03/2012

DRAWN BY
TC
REV
00
CHECKED
KYE

SAS International claims proprietary rights in the information disclosed herein. This drawing is furnished in confidence on the express understanding that neither it nor any reproduction thereof will be disclosed to others or used for the purpose of manufacture or procurement of the article or part shown hereon without the express consent in writing of SAS International. It should be understood that any article or part either made in accordance with the attached drawing or copied from an article or part made in accordance with said drawing, without the express permission in writing of SAS International, will be an infringement of the Copyright which subsists in said drawing and therefore actionable by law.
© 2010 SAS International

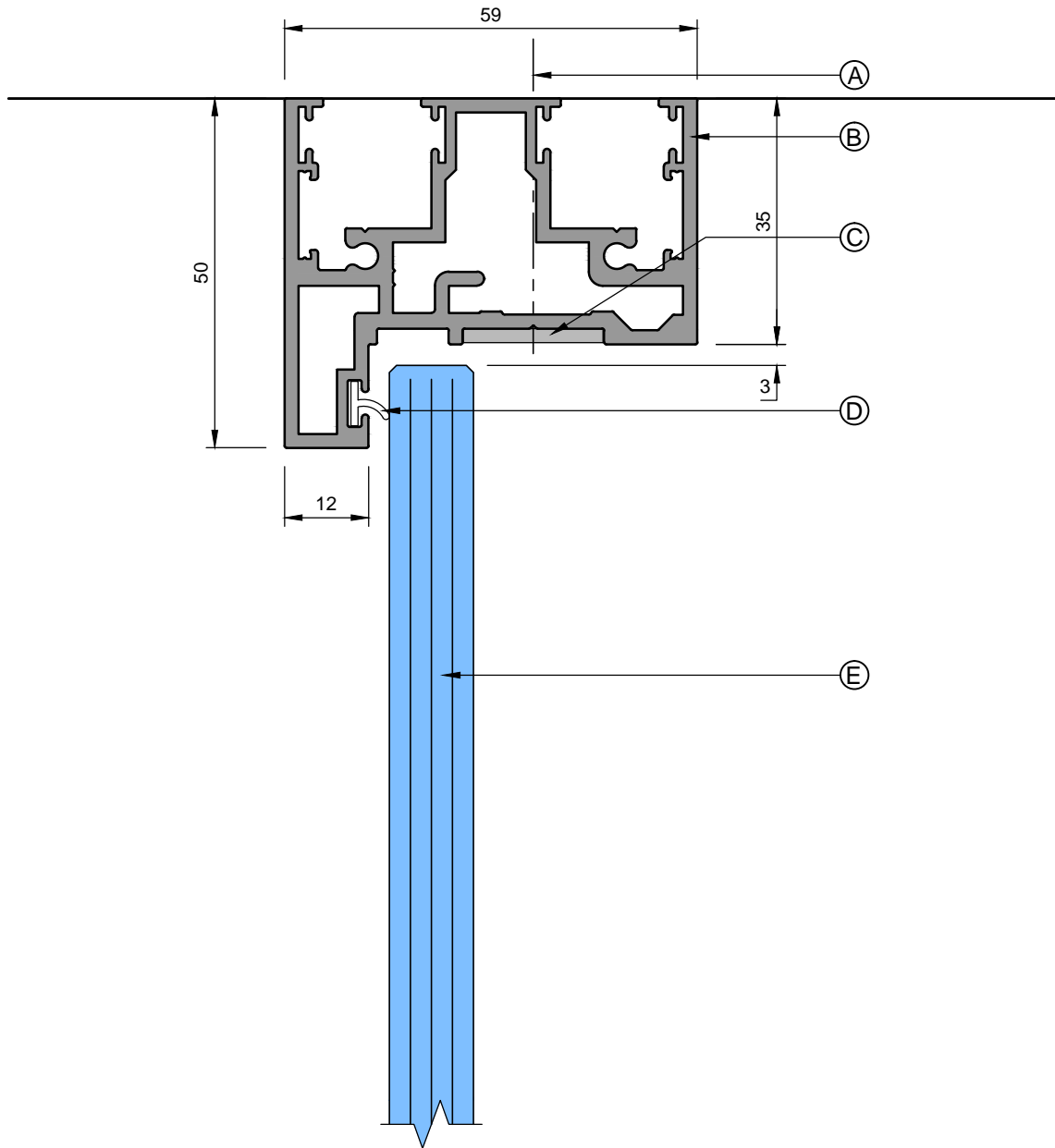

NON FIRE RATED
SEE FIRE RATED SERIES
OF DRAWINGS

- A: SUITABLE FIXINGS
- B: FG8205 SINGLE GLAZED SLIMLINE DOOR FRAME
- C: PIS20X2 OPTIONAL COVER STRIP
- D: 32037 FLIPPER SEAL
- E: 10/12mm GLASS DOOR LEAF



SAS International
31 Suttons Business Park,
London Road, Reading,
Berkshire, RG6 1AZ
Tel: 0118 929 0900
Fax: 0118 929 0908
Technical Helpline:
0118 929 0998
www.sasint.co.uk

SYSTEM 8000

58mm DOUBLE GLAZED
FG8205 DOORFRAME HEAD DETAIL

SCALE @ A4
1:1
DRG NO
PS/8200/4202
ISSUED
INFORMATION

DATE
01/03/2012

DRAWN BY
TC
REV
01
CHECKED
KYE

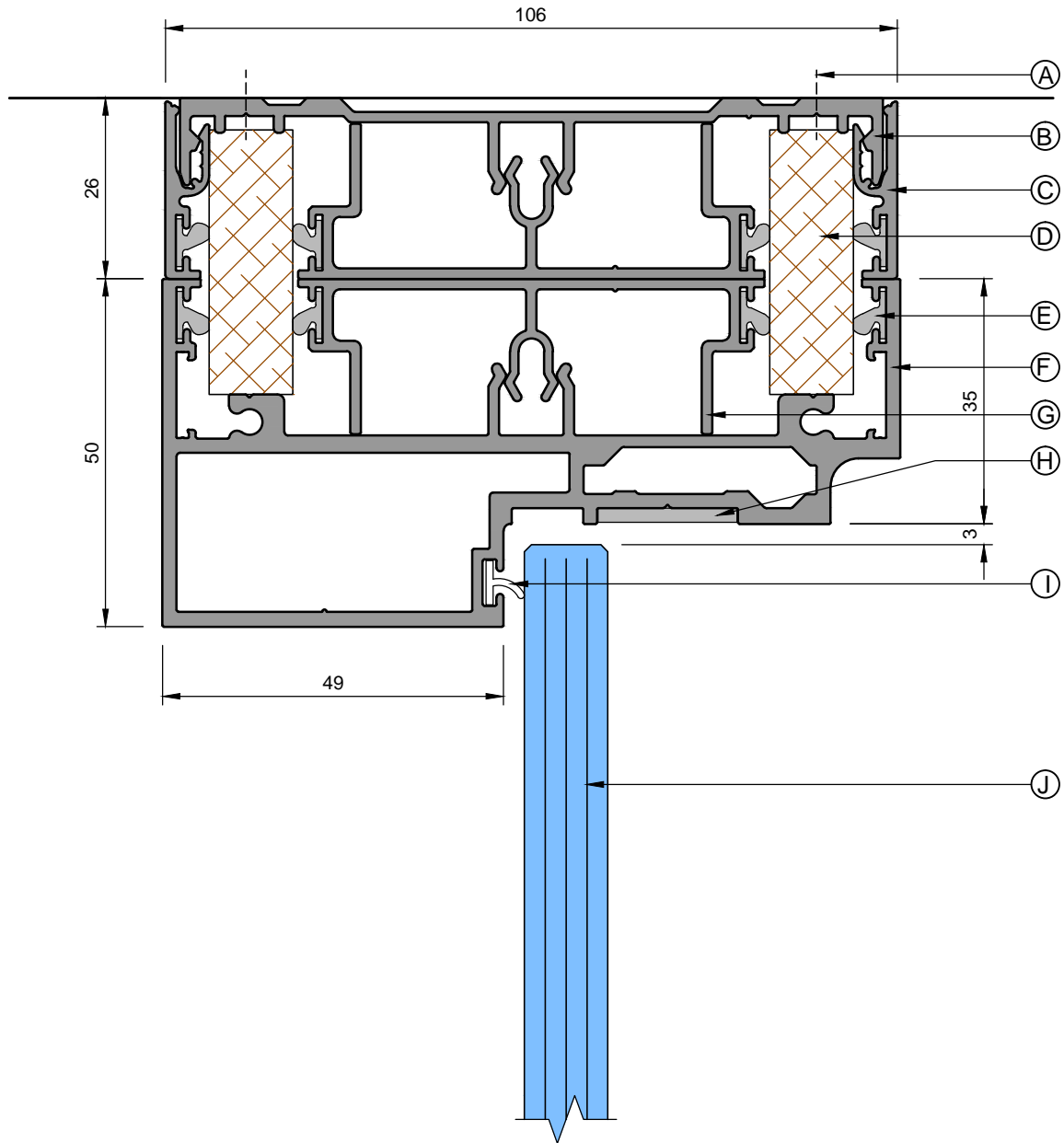

- A: SUITABLE FIXINGS
- B: FG8300 105mm DOUBLE GLAZING TRACK
- C: FG8001 GLAZING BEAD
- D: FG8007 38 x 12mm MDF HEAD PACKER
- E: 112217 Q-LON SEAL
- F: FG8307 DOUBLE GLAZED SQUARE DOOR FRAME
- G: FG8302 67mm INFILL
- H: PIS20X2 OPTIONAL COVER STRIP
- I: 32037 FLIPPER SEAL
- J: 10/12mm GLASS DOOR LEAF

NON FIRE RATED
SEE FIRE RATED SERIES
OF DRAWINGS



SAS International
31 Suttons Business Park,
London Road, Reading,
Berkshire, RG6 1AZ
Tel: 0118 929 0900
Fax: 0118 929 0908
Technical Helpline:
0118 929 0998
www.sasint.co.uk

SYSTEM 8000

105mm DOUBLE GLAZED
SQUARE DOORFRAME HEAD DETAIL

SCALE @ A4
1:1
DRG NO
PS/8300/4203
ISSUED
INFORMATION

DATE
01/03/2012

DRAWN BY
TC
REV
01
CHECKED
KYE

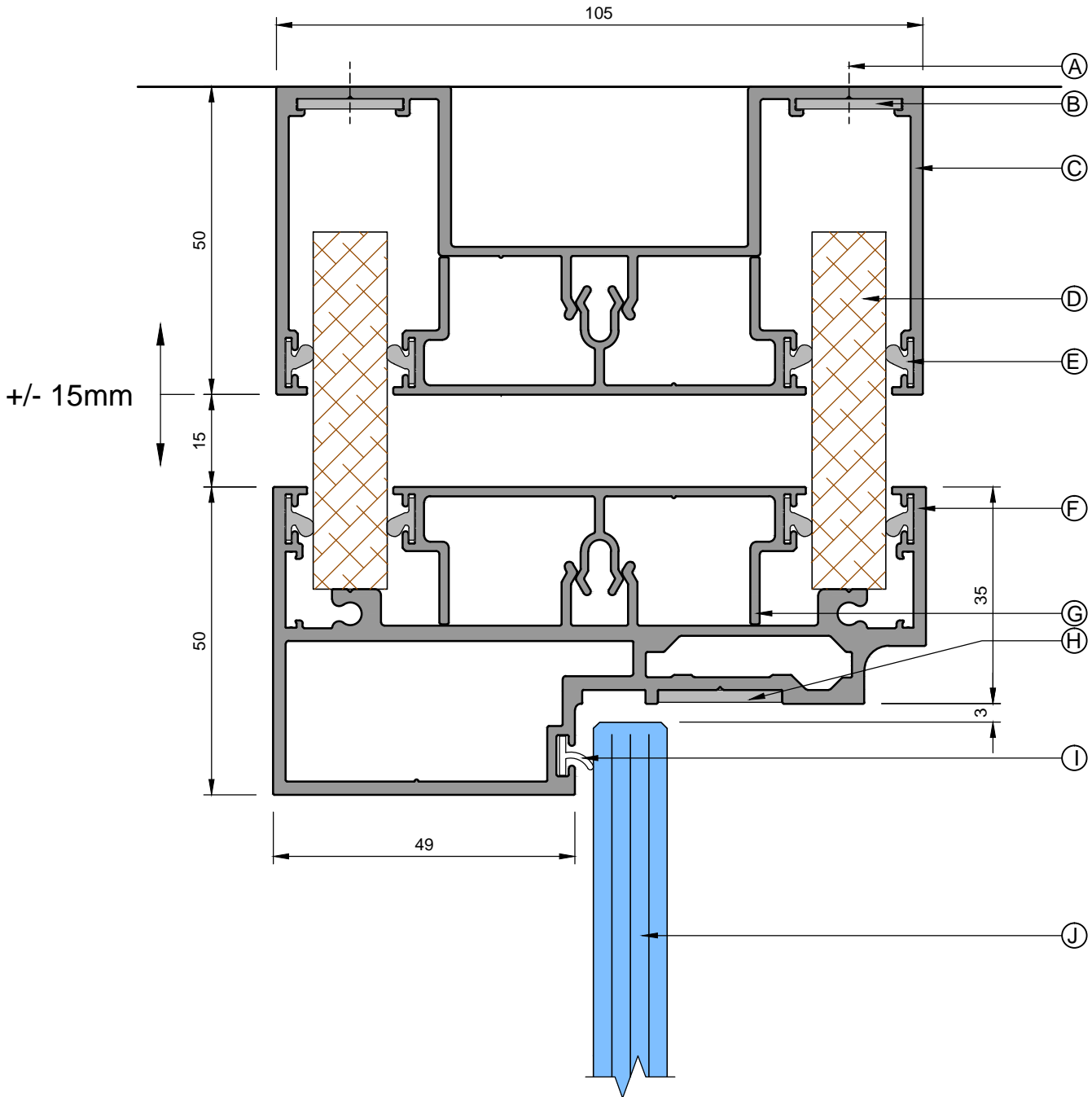

- A: SUITABLE FIXINGS
- B: 50 x 17mm SPLICE PLATE (STRAIGHT, 90° AND 135° AVAILABLE)
- C: FG8301 50mm HEAD TRACK
- D: FG8008 58 x 12mm MDF HEAD PACKER
- E: 112217 Q-LON SEAL
- F: FG8307 DOUBLE GLAZED SQUARE DOOR FRAME
- G: FG8302 67mm INFILL
- H: PIS20X2 OPTIONAL COVER STRIP
- I: 32037 FLIPPER SEAL
- J: 10/12mm GLASS DOOR LEAF

NON FIRE RATED
SEE FIRE RATED SERIES
OF DRAWINGS



SAS International
31 Suttons Business Park,
London Road, Reading,
Berkshire, RG6 1AZ
Tel: 0118 929 0900
Fax: 0118 929 0908
Technical Helpline:
0118 929 0998
www.sasint.co.uk

SYSTEM 8000

105mm DOUBLE GLAZED
FG8307 DOORFRAME HEAD DETAIL

SCALE @ A4
1:1
DRG NO
PS/8300/4204
ISSUED
INFORMATION

DATE
01/03/2012

DRAWN BY
TC
REV
01
CHECKED
KYE

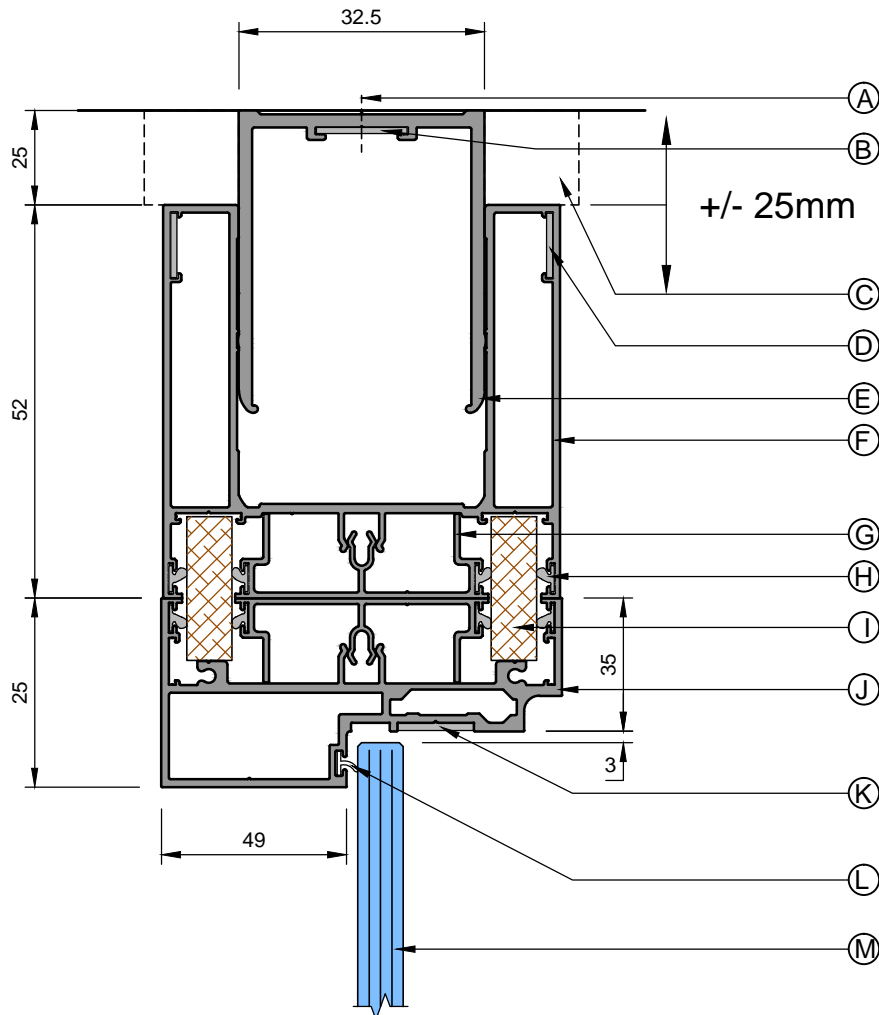

- A: SUITABLE FIXINGS
- B: 50 x 24mm SPLICE PLATE (STRAIGHT, 90° AND 135° AVAILABLE)
- C: 119476 25 x 25mm SETTING BLOCK
- D: 50 x 17mm SPLICE PLATE (STRAIGHT, 90° AND 135° AVAILABLE)
- E: DW1001 DOUBLE GLAZED DEFLECTION HEAD INNER CHANNEL
- F: FG8306 DOUBLE GLAZED DELFLECTION HEAD OUTER CHANNEL
- G: FG8302 67mm INFILL
- H: 112217 Q-LON SEAL
- I: FG8007 38 x 12mm MDF HEAD PACKER
- J: FG8307 DOUBLE GLAZED SQUARE DOORFRAME
- K: PIS20X2 OPTIONAL COVER STRIP
- L: 32037 FLIPPER SEAL
- M: 10/12mm GLASS DOOR

NON FIRE RATED
SEE FIRE RATED SERIES
OF DRAWINGS



SAS International
31 Suttons Business Park,
London Road, Reading,
Berkshire, RG6 1AZ
Tel: 0118 929 0900
Fax: 0118 929 0908
Technical Helpline:
0118 929 0998
www.sasint.co.uk

SYSTEM 8000

105mm DOUBLE GLAZED
DEFLECTION DOOR FRAME HEAD

SCALE @ A4
1:2
DRG NO
PS/8300/4205
ISSUED
INFORMATION

DATE
01/03/2012

DRAWN BY
TC
REV
01
CHECKED
KYE

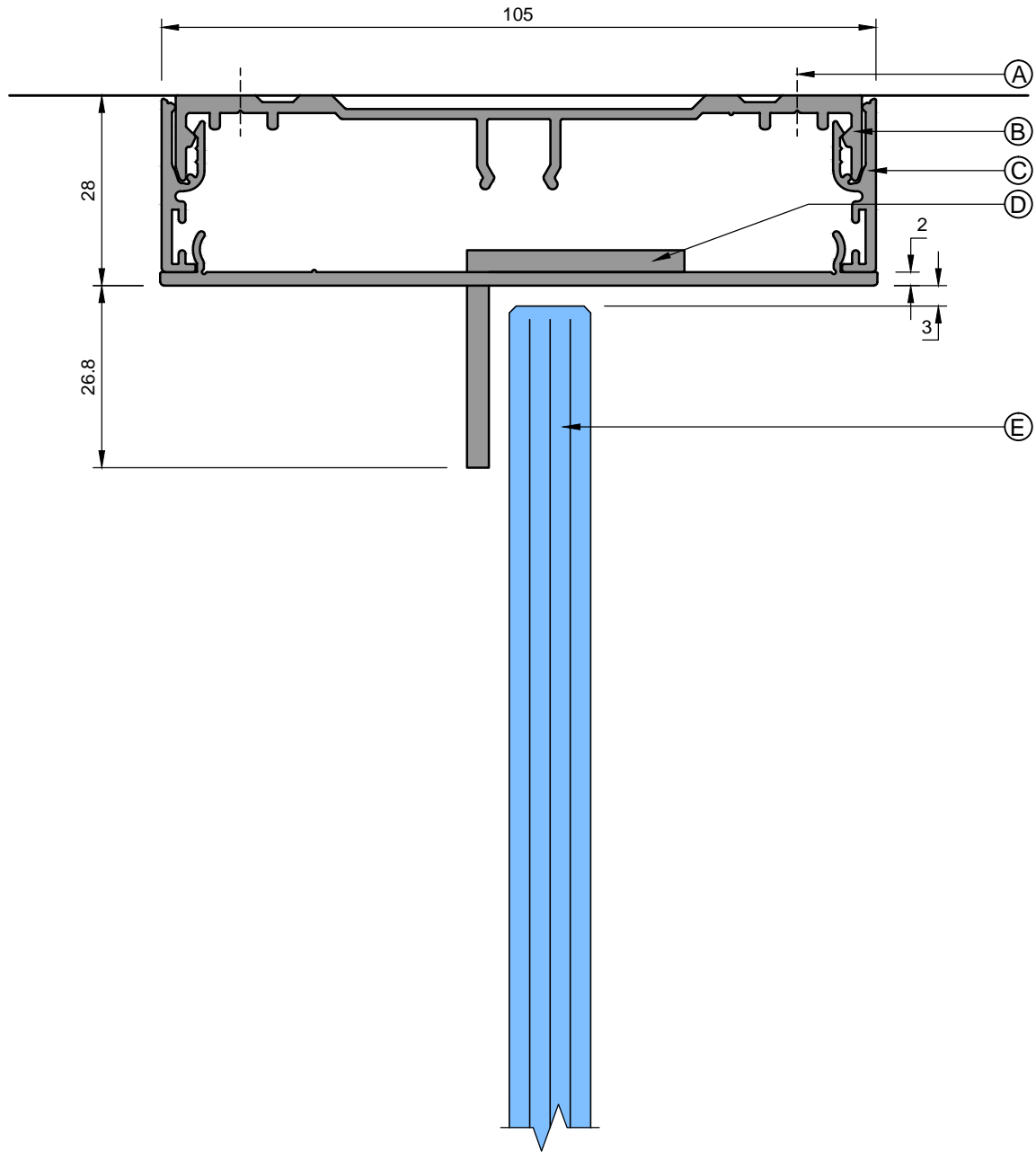

NON FIRE RATED
SEE FIRE RATED SERIES
OF DRAWINGS

- A: SUITABLE FIXINGS
- B: FG8300 DOUBLE GLAZING TRACK
- C: FG8001 GLAZING BEAD
- D: FG8312 FLAT CLIP IN SECTION (WITH WELDED ANGLE)
- E: 10/12mm GLASS DOOR LEAF

NOTE:
FOR OFFSET PIVOT DETAILS
WITH THE REDUCED DOOR
STOP HEAD PLEASE CONTACT
THE TECHNICAL DEPARTMENT



SAS International
31 Suttons Business Park,
London Road, Reading,
Berkshire, RG6 1AZ
Tel: 0118 929 0900
Fax: 0118 929 0908
Technical Helpline:
0118 929 0998
www.sasint.co.uk

SYSTEM 8000

105mm DOUBLE GLAZED
REDUCED HEAD DETAIL

SCALE @ A4
1:1
DRG NO
PS/8300/4206
ISSUED
INFORMATION

DATE
01/03/2012

DRAWN BY
TC
REV
01
CHECKED
KYE

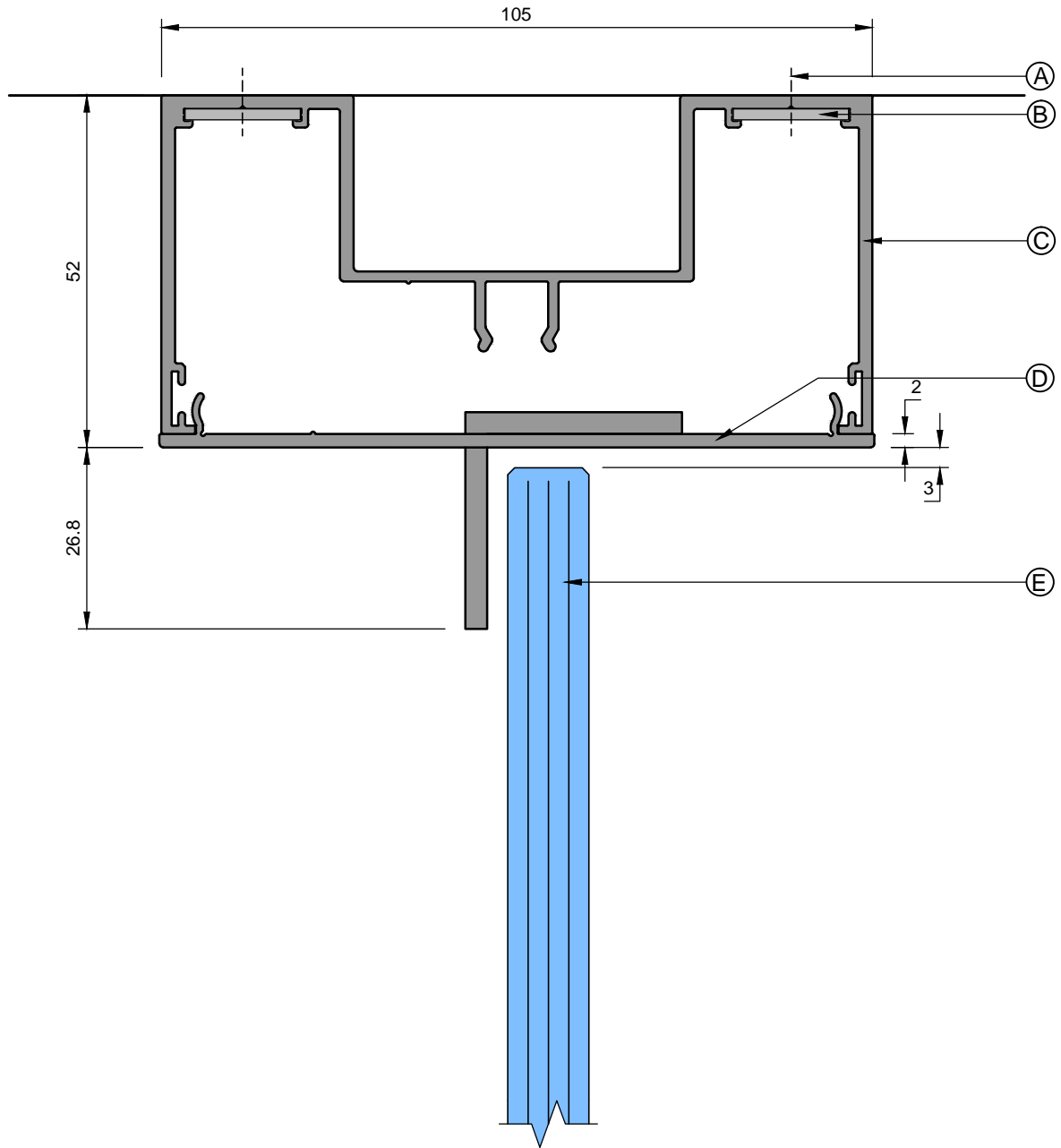

NON FIRE RATED
SEE FIRE RATED SERIES
OF DRAWINGS

- A: SUITABLE FIXINGS
- B: 50 x 17mm SPLICE PLATE (STRAIGHT, 90° AND 135° AVAILABLE)
- C: FG8301 50mm HEAD TRACK
- D: FG8311 FLAT CLIP IN SECTION
- E: 32037 FLIPPER SEAL
- F: 10/12mm GLASS DOOR LEAF

NOTE:
FOR OFFSET PIVOT DETAILS
WITH THE REDUCED DOOR
STOP HEAD PLEASE CONTACT
THE TECHNICAL DEPARTMENT



SAS International
31 Suttons Business Park,
London Road, Reading,
Berkshire, RG6 1AZ
Tel: 0118 929 0900
Fax: 0118 929 0908
Technical Helpline:
0118 929 0998
www.sasint.co.uk

SYSTEM 8000

105mm DOUBLE GLAZED
REDUCED HEAD DETAIL

SCALE @ A4
1:1
DRG NO
PS/8300/4207
ISSUED
INFORMATION

DATE
01/03/2012

DRAWN BY
TC
REV
01
CHECKED
KYE

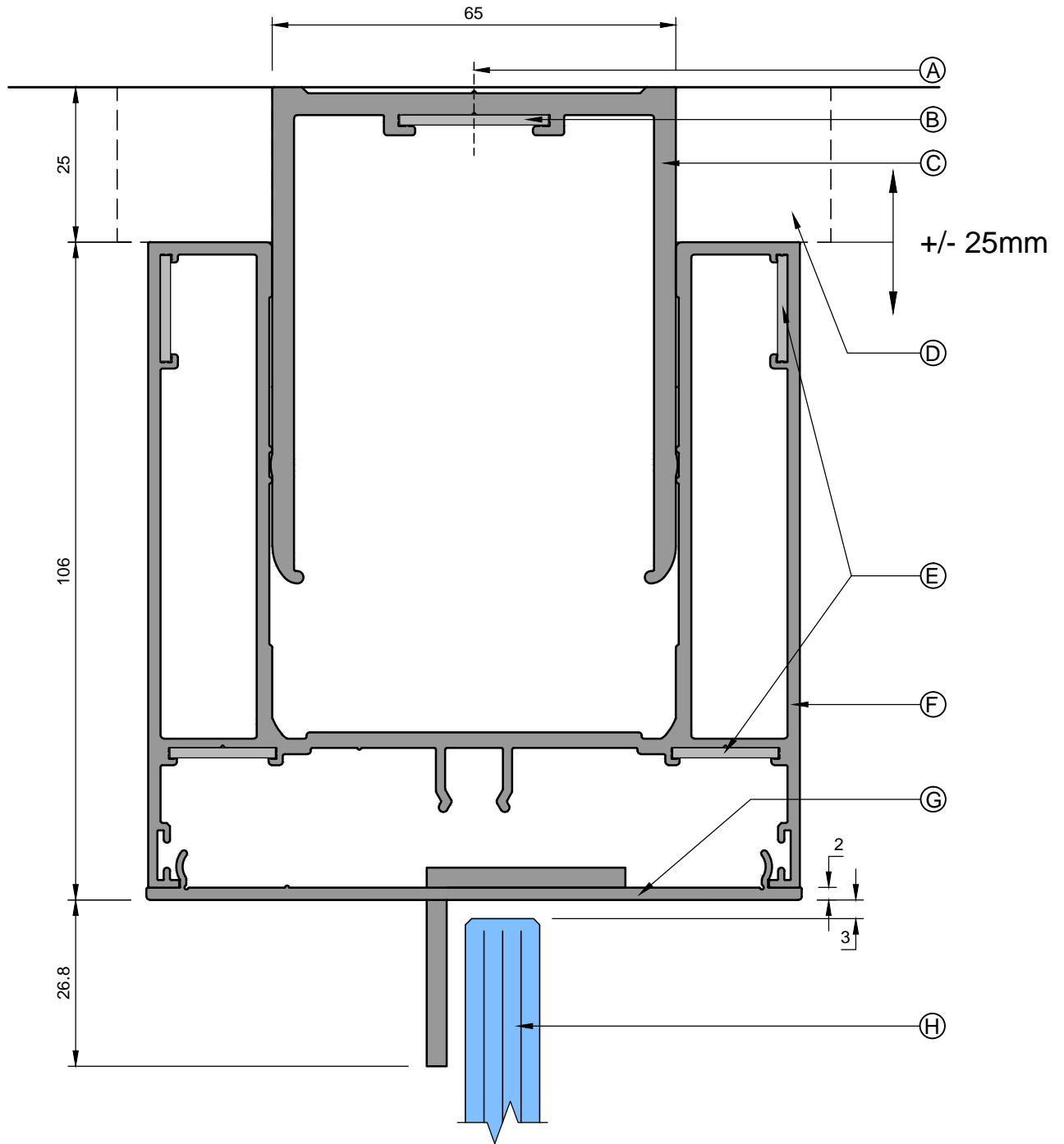

- A: SUITABLE FIXINGS
- B: 50 x 24mm SPLICE PLATE (STRAIGHT, 90° AND 135° AVAILABLE)
- C: DW1001 DOUBLE GLAZED DEFLECTION HEAD INNER CHANNEL
- D: 119476 25 x 25mm SETTING BLOCK
- E: 50 x 17mm SPLICE PLATE (STRAIGHT, 90° AND 135° AVAILABLE)
- F: FG8306 DOUBLE GLAZED DEFLECTION HEAD OUTER CHANNEL
- G: FG8311 FLAT CLIP IN SECTION
- H: 10/12mm GLASS DOOR LEAF

NOTE:
FOR OFFSET PIVOT DETAILS
WITH THE REDUCED DOOR
STOP HEAD PLEASE CONTACT
THE TECHNICAL DEPARTMENT

NON FIRE RATED
SEE FIRE RATED SERIES
OF DRAWINGS



SAS International
31 Suttons Business Park,
London Road, Reading,
Berkshire, RG6 1AZ
Tel: 0118 929 0900
Fax: 0118 929 0908
Technical Helpline:
0118 929 0998
www.sasint.co.uk

SYSTEM 8000

105mm DOUBLE GLAZED
REDUCED HEAD DETAIL

SCALE @ A4

1:1

DRG NO

PS/8300/4208

ISSUED

INFORMATION

DATE

01/03/2012

DRAWN BY

TC

REV

01

CHECKED

KYE

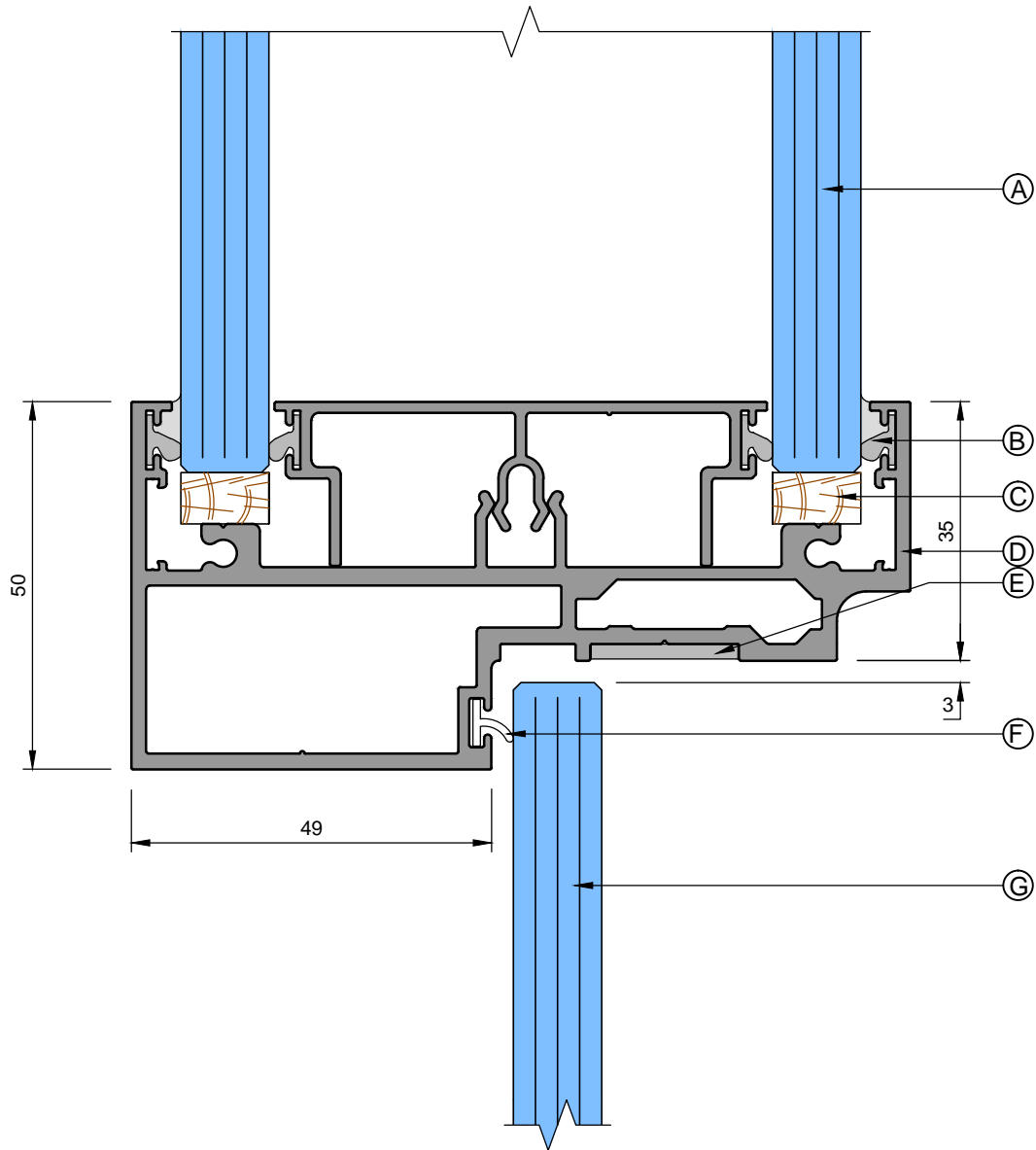

- A: 10/12mm GLASS
- B: 112217 Q-LON SEAL
- C: 111637 TIMBER PACKER FOR GLAZING ABOVE DOOR
- D: FG8307 DOUBLE GLAZED SQUARE DOOR FRAME
- E: PIS20X2 OPTIONAL COVER STRIP
- F: 32037 FLIPPER SEAL
- G: 10/12mm GLASS DOOR LEAF

NON FIRE RATED

SEE FIRE RATED SERIES OF DRAWINGS



SAS International
 31 Suttons Business Park,
 London Road, Reading,
 Berkshire, RG6 1AZ
 Tel: 0118 929 0900
 Fax: 0118 929 0908
 Technical Helpline:
 0118 929 0998
 www.sasint.co.uk

SYSTEM 8000

105mm DOUBLE GLAZED
 DOOR FRAME WITH GLASS ABOVE

SCALE @ A4
 1:1
 DRG NO
 PS/8300/4209
 ISSUED
 INFORMATION

DATE
 01/03/2012

DRAWN BY
 TC
 REV
 01
 CHECKED
 KYE

PLEASE REFER TO
SUBSEQUENT DRAWINGS
FOR HINGED GLASS
DOOR JAMB OPTIONS

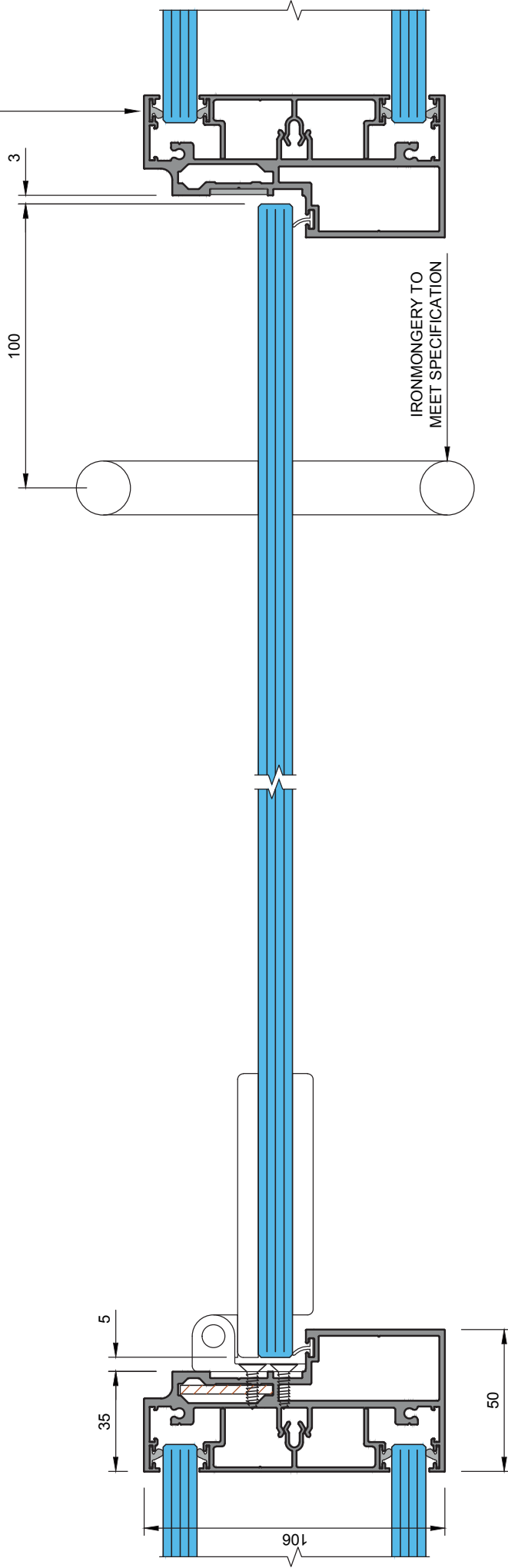

NON FIRE RATED
SEE FIRE RATED SERIES
OF DRAWINGS



SAS International
London Road, Reading,
Berkshire, RG6 1AZ
UK
Tel: 0118 929 0800
Fax: 0118 929 0809
Technical Hotline:
0118 929 0808
www.sasint.co.uk

SAS International claims proprietary rights in the information disclosed hereon. This drawing is furnished in confidence on the express understanding that neither it nor any reproduction thereof will be disclosed to others or used for the purpose of manufacture or other similar activity without the express written permission of SAS International. It should be understood that any article or part either made in accordance with the attached drawing or copied from an article or part made in accordance with said drawing, without the express permission in writing of SAS International, will be an infringement of the Copyright in said drawing and therefore actionable by SAS.
© 2010 SAS International

SYSTEM 8000
105mm DOUBLE GLAZED
FG8307 DOOR FRAME SECTION VIEW

SCALE @ A4
1:2
DRG NO
PS/8300/4300
ISSUED INFORMATION

DATE
01/03/2012

DRAWN BY
TC
REV
00
CHECKED
KYE

PLEASE REFER TO
SUBSEQUENT DRAWINGS
FOR HINGED GLASS
DOOR JAMB OPTIONS

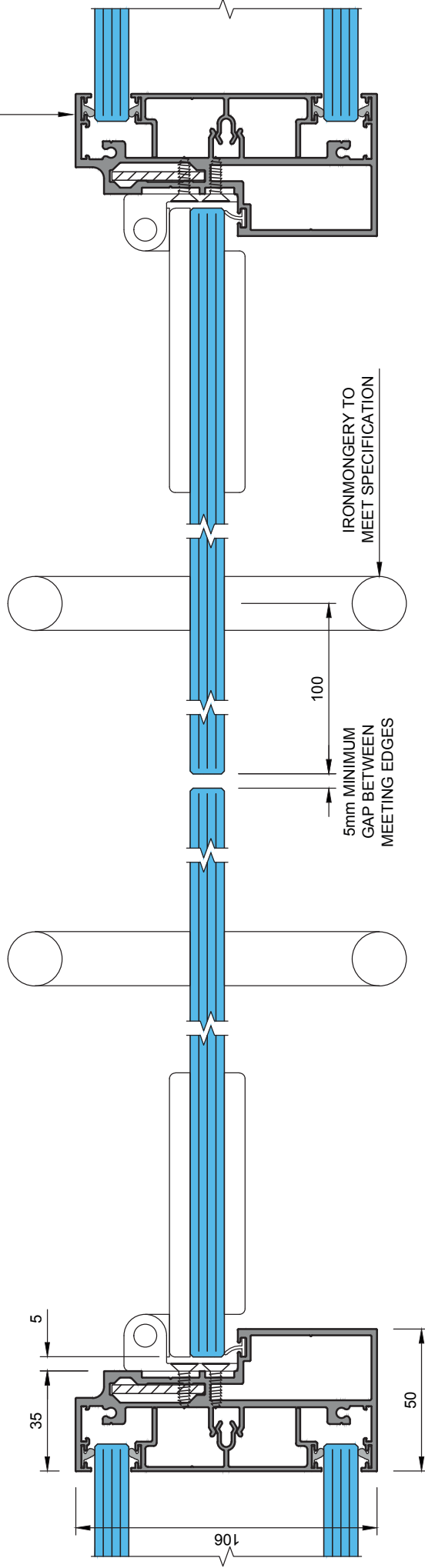

NON FIRE RATED
SEE FIRE RATED SERIES
OF DRAWINGS



SAS International
The Old Mill, Mill Lane,
London Road, Reading,
Berks, RG6 7AZ
UK
Tel: 0118 922 0909
Fax: 0118 922 0908
Technical Hotline:
0118 922 0909
www.sasint.co.uk

SAS International claims proprietary rights in the information disclosed herein. This drawing is furnished in confidence on the express understanding that neither it nor any reproduction thereof will be disclosed to others or used for the purpose of manufacture or sale of any product or service without the express written consent of SAS International. It should be understood that any article or part either made in accordance with the attached drawing or copied from an article or part made in accordance with said drawing, without the express written consent of SAS International, will be an infringement of the copyright subsisting in said drawing and therefore actionable by SAS International.
© 2010 SAS International

SYSTEM 8000
105mm DOUBLE GLAZED
FG8307 DOOR FRAME SECTION VIEW

SCALE @ A4 1:2
DRG NO PS/8300/4301
ISSUED INFORMATION
DATE 01/03/2012
DRAWN BY TC
REV 00
CHECKED KYE

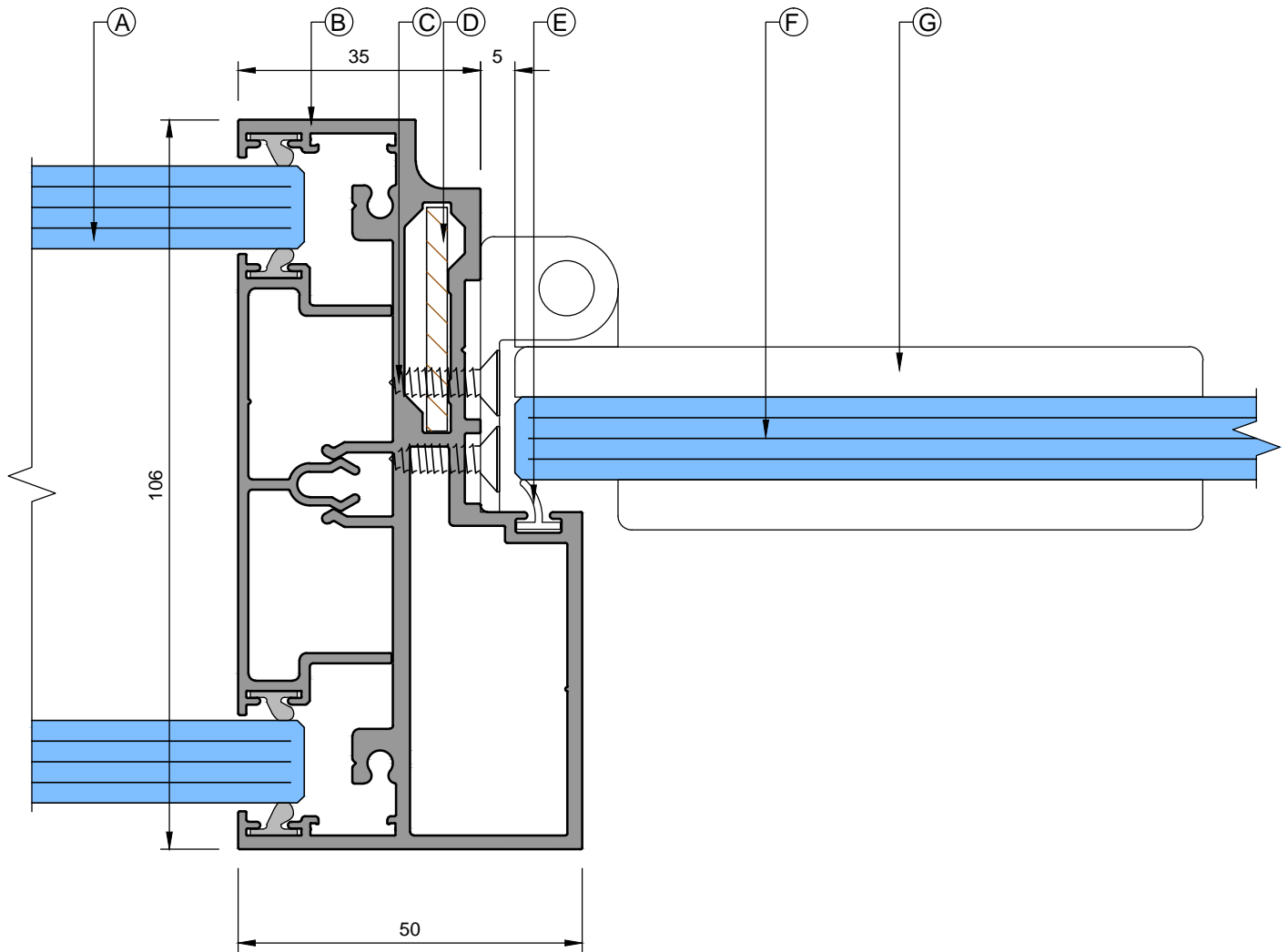

- A: 10/12mm GLASS (NOMINAL GLASS THICKNESS SHOWN)
- B: FG8307 DOUBLE GLAZED SQUARE DOOR FRAME
- C: 4.2 x 16mm C'SUNK SELF TAPPER
- D: DOOR FRAME PLYWOOD INFILL
- E: 116117 GLASS DOOR FLIPPER SEAL
- F: 10/12mm GLASS DOOR LEAF
- G: PATCH HINGE

NON FIRE RATED
SEE FIRE RATED SERIES
OF DRAWINGS



SAS International
31 Suttons Business Park,
London Road, Reading,
Berkshire, RG6 1AZ
Tel: 0118 929 0900
Fax: 0118 929 0908
Technical Helpline:
0118 929 0998
www.sasint.co.uk

SYSTEM 8000

105mm DOUBLE GLAZED
FG8307 DOOR FRAME JAMB

SCALE @ A4
1:1
DRG NO
PS/8300/4302
ISSUED
INFORMATION

DATE
01/03/2012

DRAWN BY
TC
REV
01
CHECKED
KYE

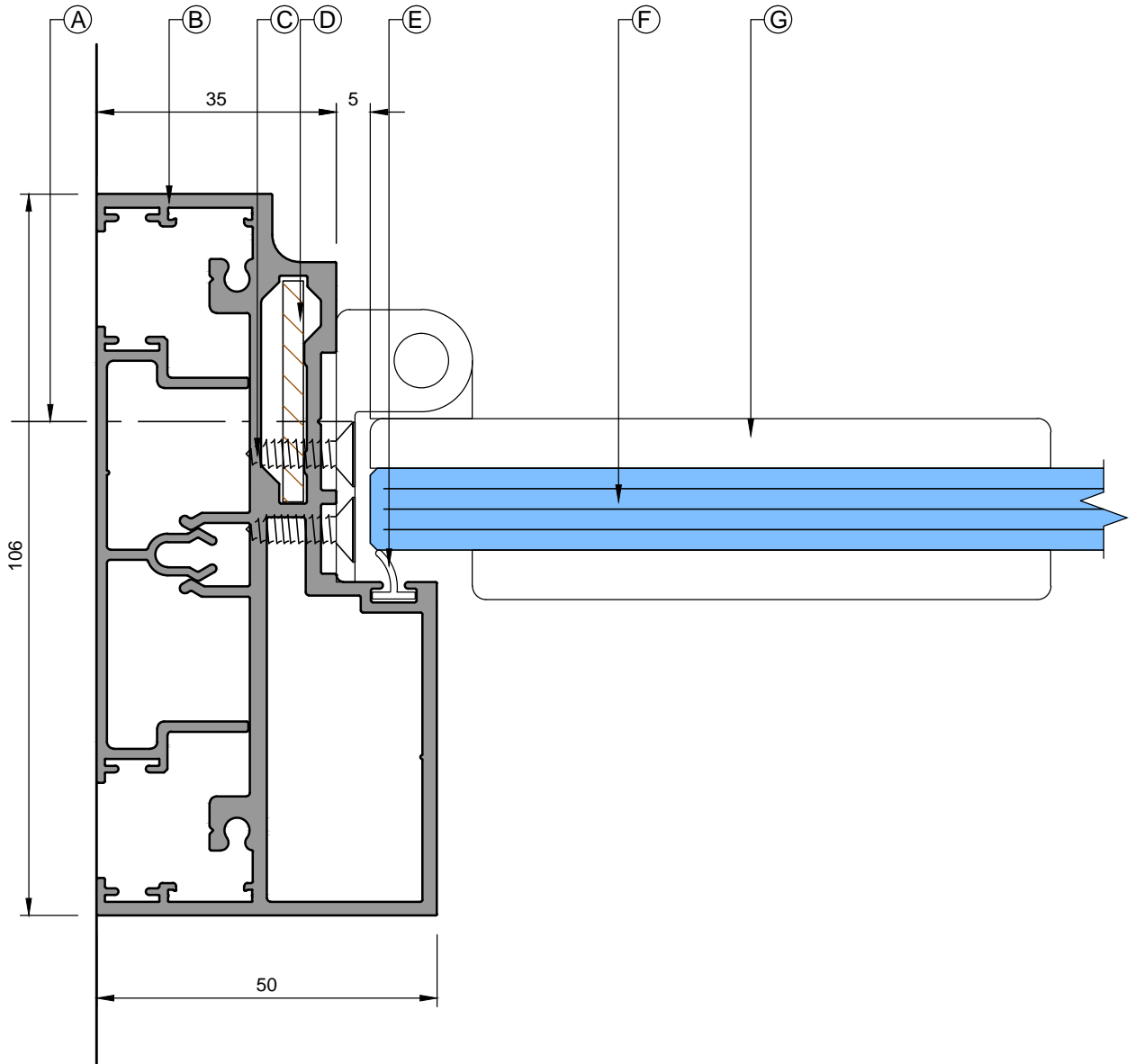

- A: SUITABLE FIXINGS
- B: FG8307 DOUBLE GLAZED SQUARE DOOR FRAME
- C: 4.2 x 16mm C'SUNK SELF TAPPER
- D: DOOR FRAME PLYWOOD INFILL
- E: 116117 GLASS DOOR FLIPPER SEAL
- F: 10/12mm GLASS DOOR LEAF
- G: PATCH HINGE

NON FIRE RATED

SEE FIRE RATED SERIES OF DRAWINGS



SAS International
 31 Suttons Business Park,
 London Road, Reading,
 Berkshire, RG6 1AZ
 Tel: 0118 929 0900
 Fax: 0118 929 0908
 Technical Helpline:
 0118 929 0998
 www.sasint.co.uk

SYSTEM 8000

105mm DOUBLE GLAZED
 FG8307 DOOR FRAME WALL ABUTMENT

SCALE @ A4
 1:1
 DRG NO
 PS/8300/4303
 ISSUED
 INFORMATION

DATE
 01/03/2012

DRAWN BY
 TC
 REV
 01
 CHECKED
 KYE

door frame details (timber doors)

Drawing description	Drawing number
Hinged Timber Door Leaf Vertical Section	PS/8300/5200
Door Frame Head Detail	PS/8300/5201
Two Part Door Frame Head Detail.....	PS/8300/5202
50mm Door Frame Head Detail	PS/8300/5203
Deflection Door Frame Head Detail.....	PS/8300/5204
Two Part Reduced Head Detail	PS/8300/5205
50mm Reduced Head Detail.....	PS/8300/5206
Deflection Reduced Head Detail.....	PS/8300/5207
Door Frame With Glass Above (10/12mm Glass).....	PS/8300/5208
Single Hinged Timber Door Leaf Horizontal Section.....	PS/8300/5300
Double Hinged Timber Door Leaf Horizontal Section.....	PS/8300/5301
Door Frame Jamb (10/12mm Glass)	PS/8300/5302
Door Frame Wall Abutment.....	PS/8300/5303

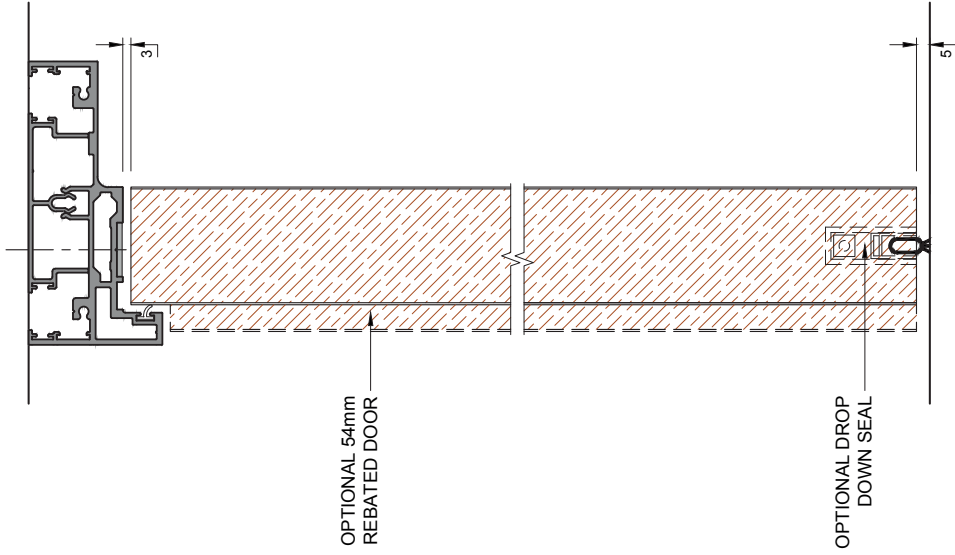

OPTIONAL 54mm
REBATED DOOR

OPTIONAL DROP
DOWN SEAL

FULL HEIGHT DOOR FRAME (12mm DOOR STOP)
WITH OPTIONAL 54mm REBATED DOOR

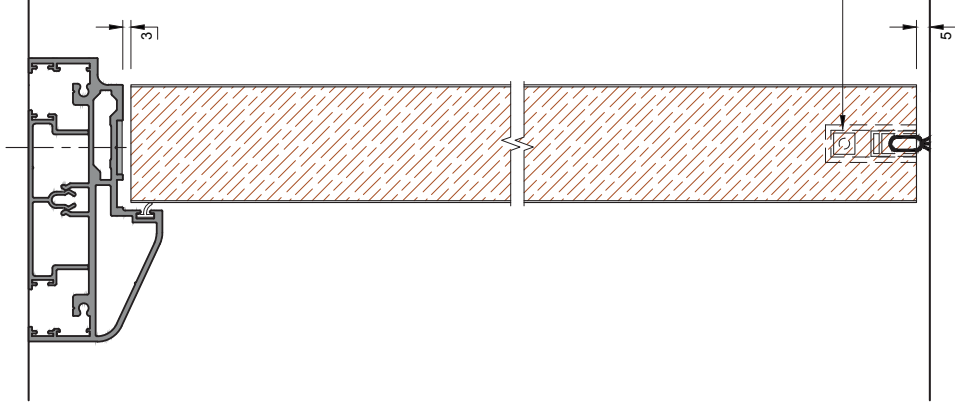

OPTIONAL DROP
DOWN SEAL

FULL HEIGHT CHAMFERED DOOR FRAME

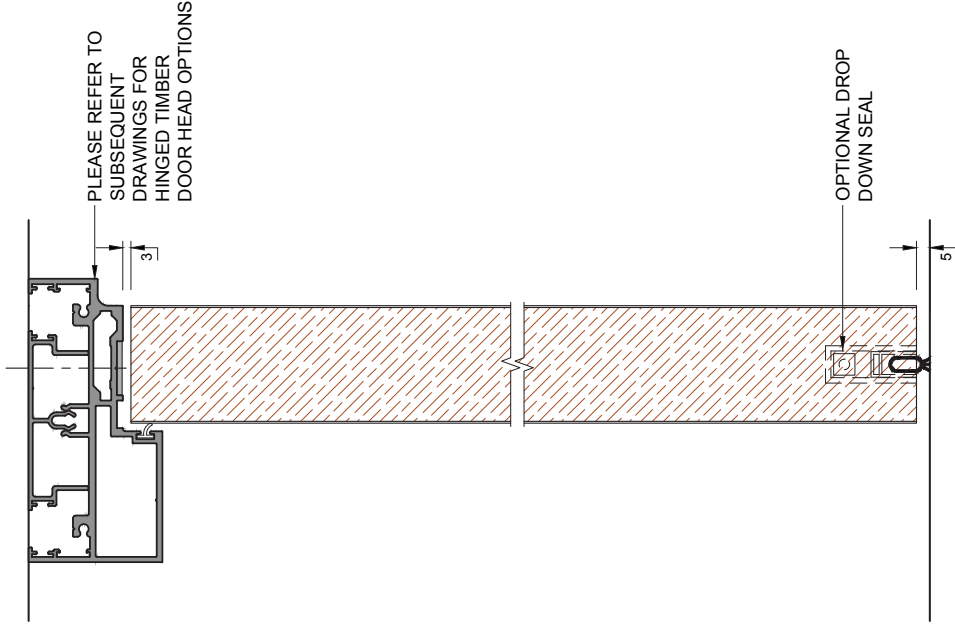

OPTIONAL DROP
DOWN SEAL

FULL HEIGHT SQUARE DOOR FRAME

PLEASE REFER TO
SUBSEQUENT
DRAWINGS FOR
HINGED TIMBER
DOOR HEAD OPTIONS

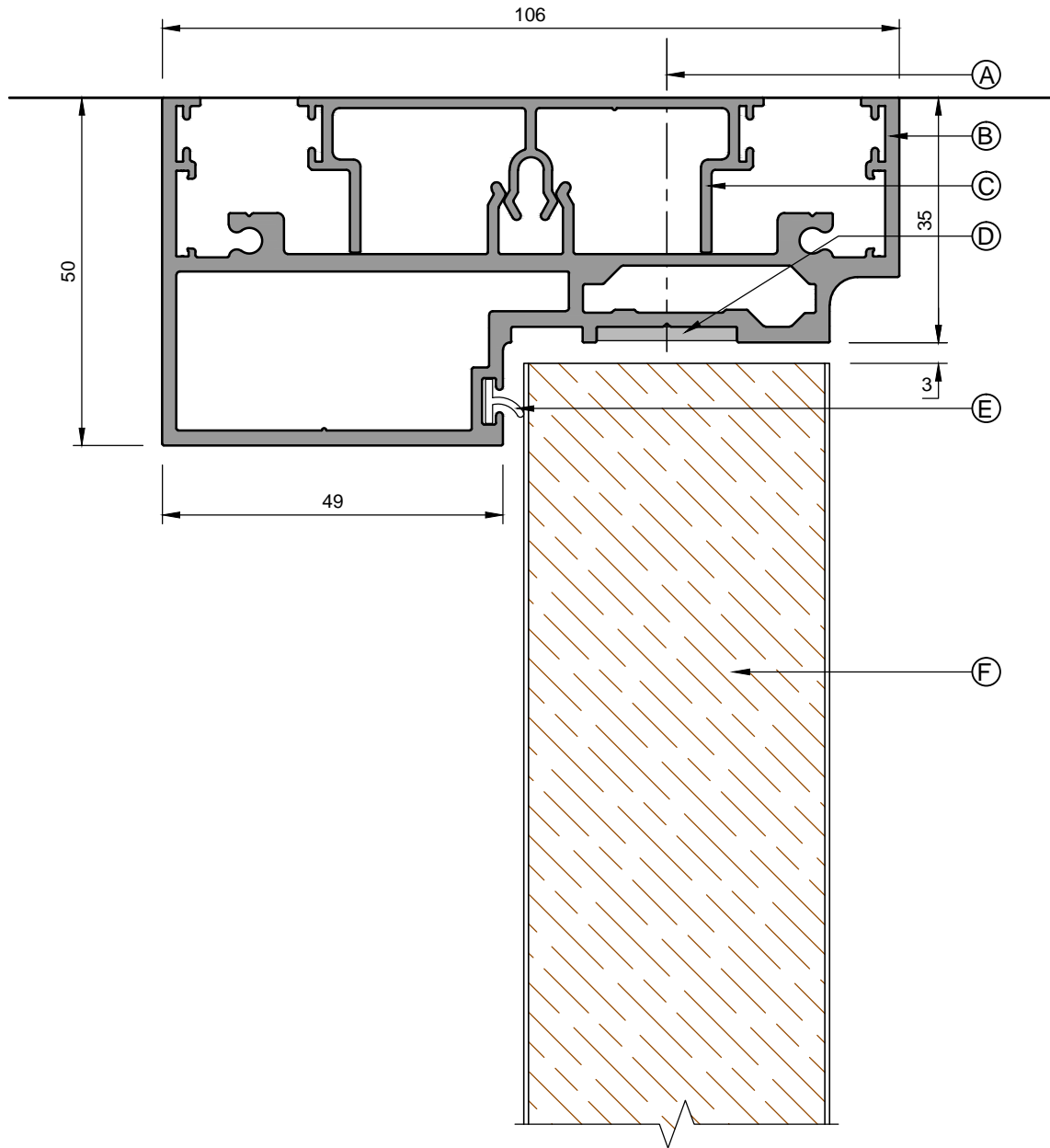

NON FIRE RATED
SEE FIRE RATED SERIES
OF DRAWINGS

- A: SUITABLE FIXINGS
- B: FG8307 DOUBLE GLAZED SQUARE DOOR FRAME
- C: FG8302 67mm INFILL
- D: PIS20X2 OPTIONAL COVER STRIP
- E: 32037 FLIPPER SEAL
- F: 10/12mm GLASS DOOR LEAF



SAS International
31 Suttons Business Park,
London Road, Reading,
Berkshire, RG6 1AZ
Tel: 0118 929 0900
Fax: 0118 929 0908
Technical Helpline:
0118 929 0998
www.sasint.co.uk

SYSTEM 8000

105mm DOUBLE GLAZED
FG8307 DOORFRAME HEAD DETAIL

SCALE @ A4
1:1
DRG NO
PS/8300/5201
ISSUED
INFORMATION

DATE
01/03/2012

DRAWN BY
TC
REV
01
CHECKED
KYE

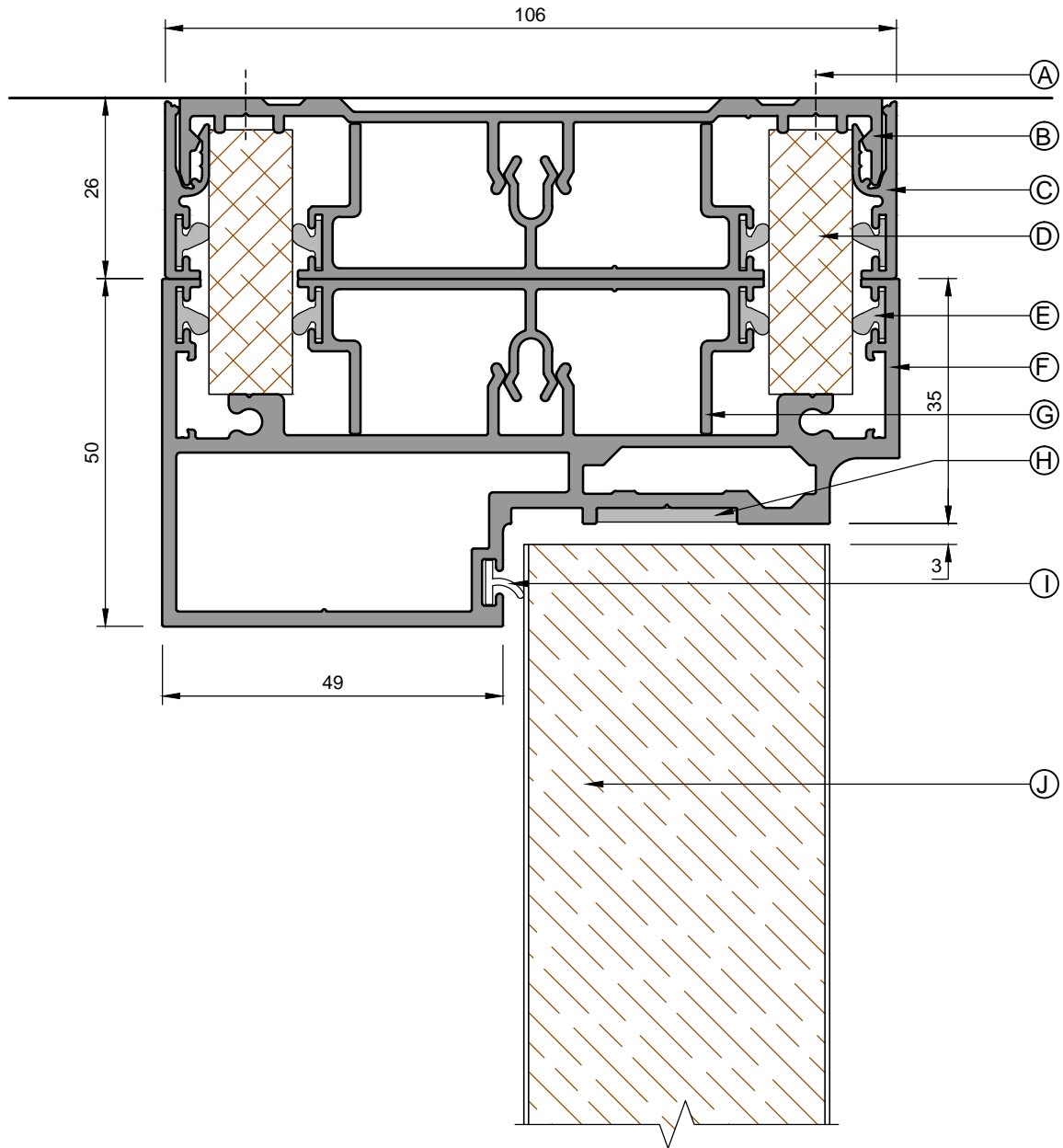

- A: SUITABLE FIXINGS
- B: FG8300 105mm DOUBLE GLAZING TRACK
- C: FG8001 GLAZING BEAD
- D: FG8007 38 x 12mm MDF HEAD PACKER
- E: 112217 Q-LON SEAL
- F: FG8307 DOUBLE GLAZED SQUARE DOOR FRAME
- G: FG8302 67mm INFILL
- H: PIS20X2 OPTIONAL COVER STRIP
- I: 32037 FLIPPER SEAL
- J: 44mm TIMBER DOOR LEAF

NON FIRE RATED
SEE FIRE RATED SERIES
OF DRAWINGS



SAS International
31 Suttons Business Park,
London Road, Reading,
Berkshire, RG6 1AZ
Tel: 0118 929 0900
Fax: 0118 929 0908
Technical Helpline:
0118 929 0998
www.sasint.co.uk

SYSTEM 8000

105mm DOUBLE GLAZED
SQUARE DOORFRAME HEAD DETAIL

SCALE @ A4
1:1
DRG NO
PS/8300/5202
ISSUED
INFORMATION

DATE
01/03/2012

DRAWN BY
TC
REV
01
CHECKED
KYE

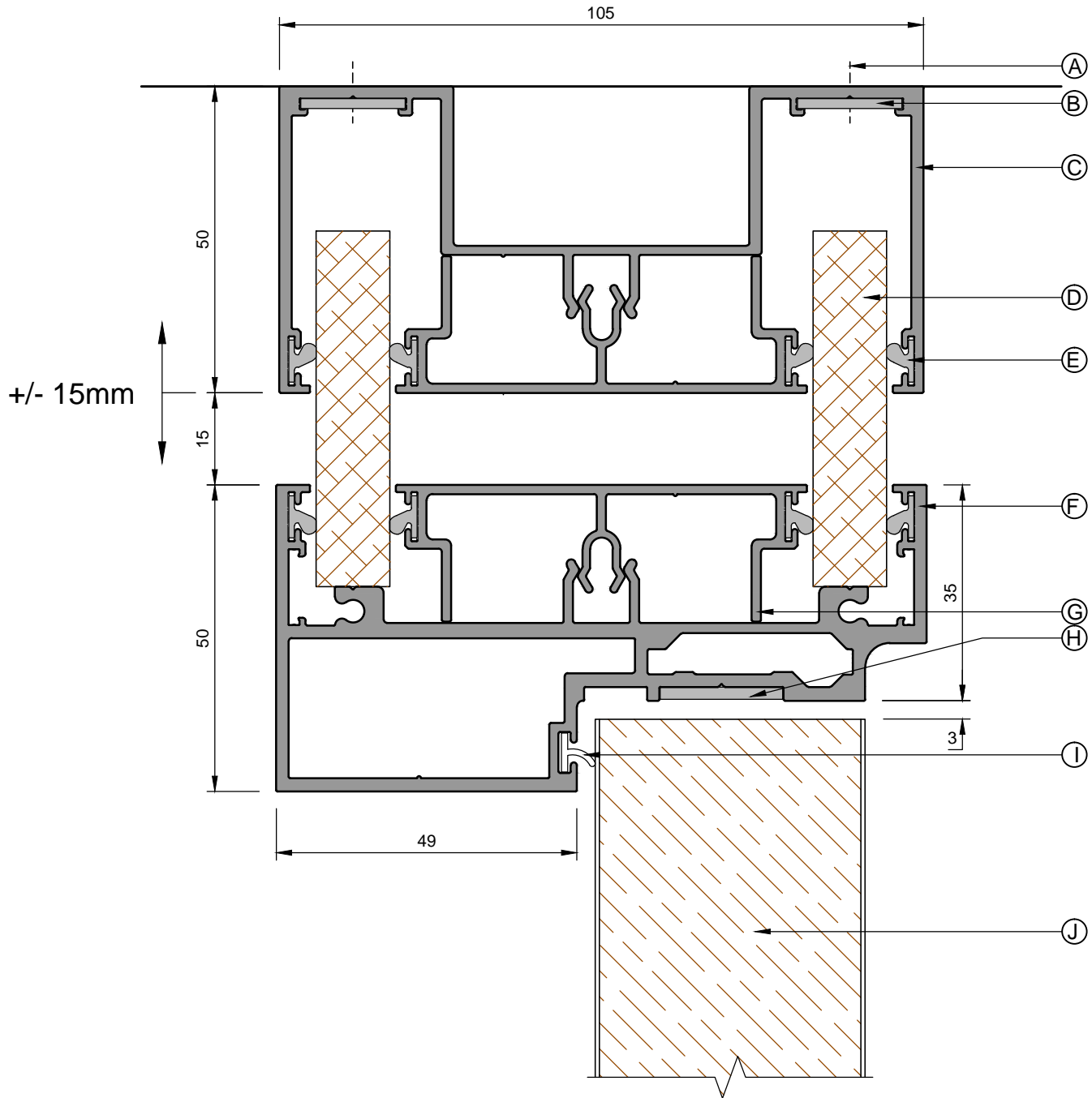

- A: SUITABLE FIXINGS
- B: 50 x 17mm SPLICE PLATE (STRAIGHT, 90° AND 135° AVAILABLE)
- C: FG8301 50mm HEAD TRACK
- D: FG8008 58 x 12mm MDF HEAD PACKER
- E: 112217 Q-LON SEAL
- F: FG8307 DOUBLE GLAZED SQUARE DOOR FRAME
- G: FG8302 67mm INFILL
- H: PIS20X2 OPTIONAL COVER STRIP
- I: 32037 FLIPPER SEAL
- J: 44mm TIMBER DOOR LEAF

NON FIRE RATED
SEE FIRE RATED SERIES
OF DRAWINGS



SAS International
31 Suttons Business Park,
London Road, Reading,
Berkshire, RG6 1AZ
Tel: 0118 929 0900
Fax: 0118 929 0908
Technical Helpline:
0118 929 0998
www.sasint.co.uk

SYSTEM 8000

105mm DOUBLE GLAZED
FG8307 DOORFRAME HEAD DETAIL

SCALE @ A4
1:1
DRG NO
PS/8300/5203
ISSUED
INFORMATION

DATE
01/03/2012

DRAWN BY
TC
REV
01
CHECKED
KYE

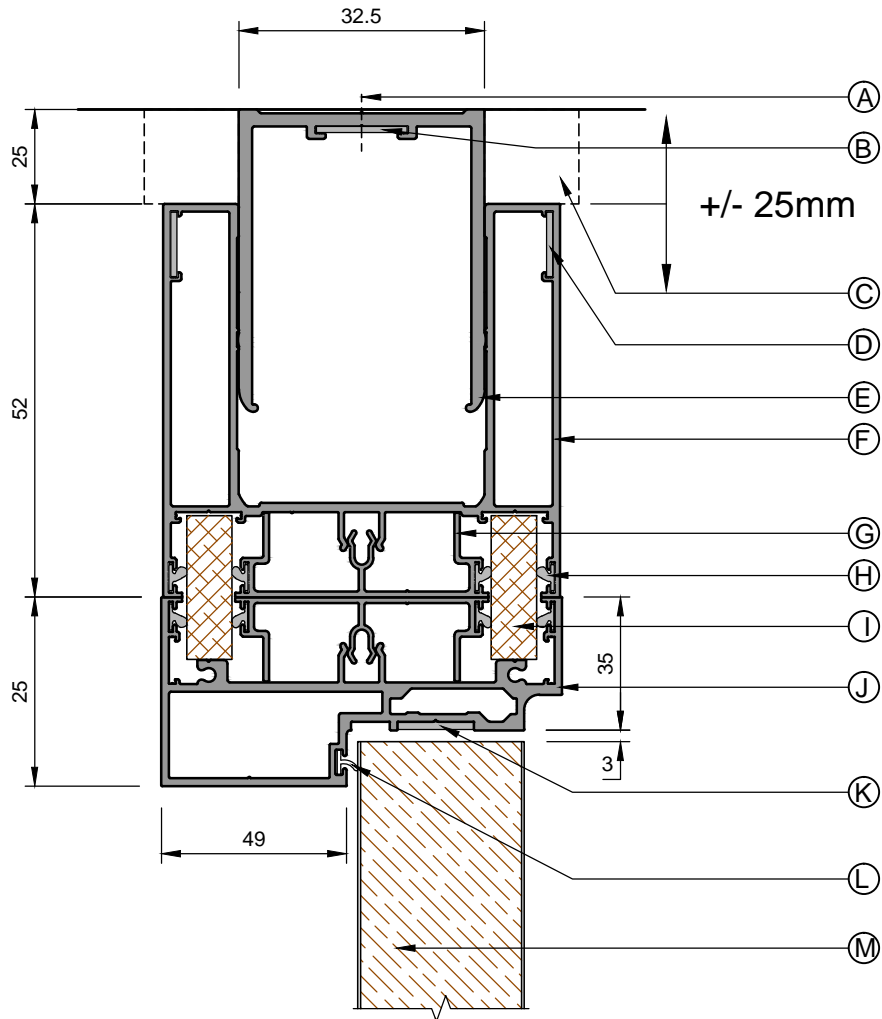

- A: SUITABLE FIXINGS
- B: 50 x 24mm SPLICE PLATE (STRAIGHT, 90° AND 135° AVAILABLE)
- C: 119476 25 x 25mm SETTING BLOCK
- D: 50 x 17mm SPLICE PLATE (STRAIGHT, 90° AND 135° AVAILABLE)
- E: DW1001 DOUBLE GLAZED DEFLECTION HEAD INNER CHANNEL
- F: FG8306 DOUBLE GLAZED DELFLECTION HEAD OUTER CHANNEL
- G: FG8302 67mm INFILL
- H: 112217 Q-LON SEAL
- I: FG8007 38 x 12mm MDF HEAD PACKER
- J: FG8307 DOUBLE GLAZED SQUARE DOORFRAME
- K: PIS20X2 OPTIONAL COVER STRIP
- L: 32037 FLIPPER SEAL
- M: 44mm TIMBER DOOR LEAF

NON FIRE RATED
SEE FIRE RATED SERIES
OF DRAWINGS



SAS International
31 Suttons Business Park,
London Road, Reading,
Berkshire, RG6 1AZ
Tel: 0118 929 0900
Fax: 0118 929 0908
Technical Helpline:
0118 929 0998
www.sasint.co.uk

SYSTEM 8000

105mm DOUBLE GLAZED
DEFLECTION DOOR FRAME HEAD

SCALE @ A4
1:2
DRG NO
PS/8300/5204
ISSUED
INFORMATION

DATE
01/03/2012

DRAWN BY
TC
REV
01
CHECKED
KYE

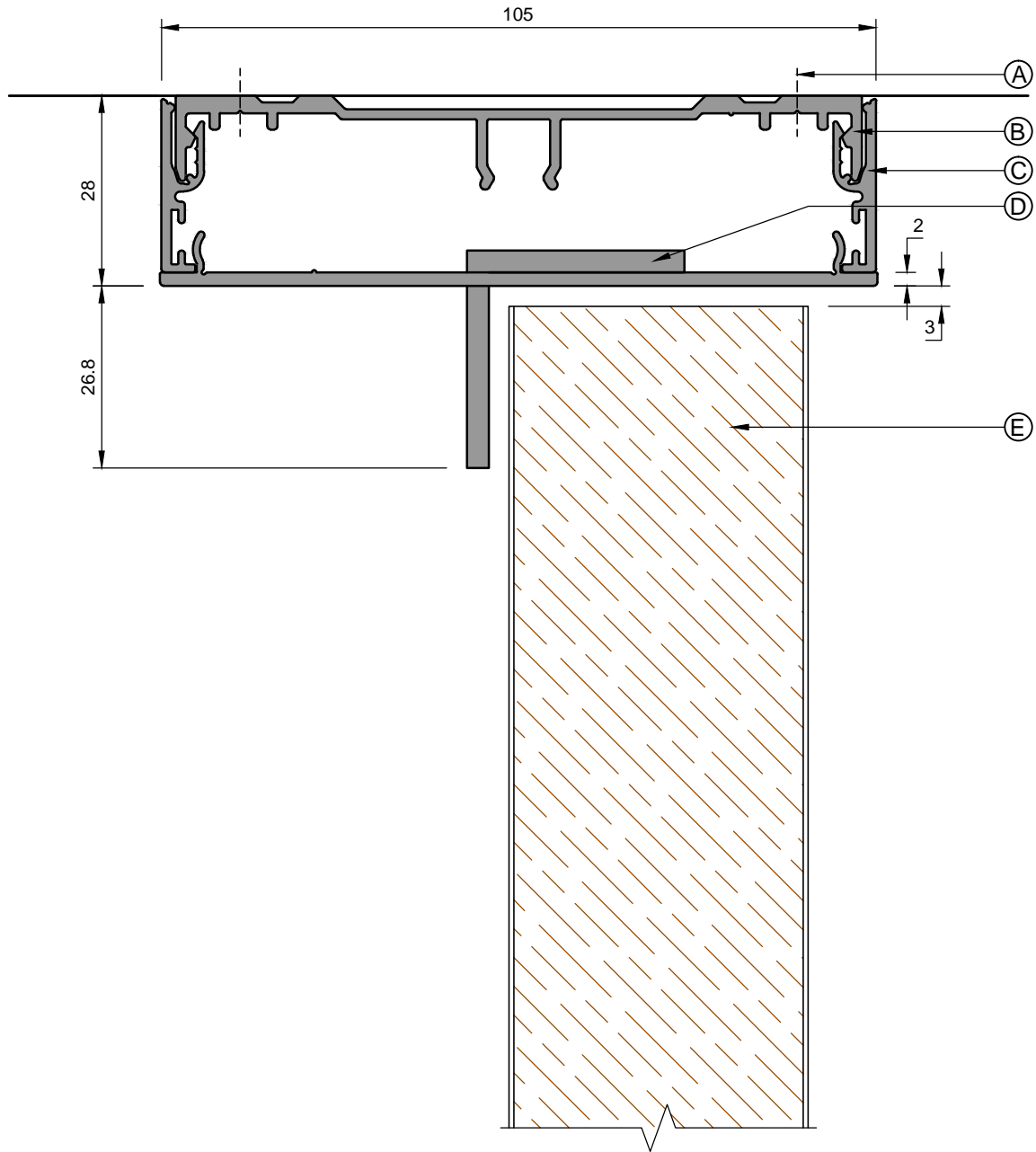

NON FIRE RATED
SEE FIRE RATED SERIES
OF DRAWINGS

- A: SUITABLE FIXINGS
- B: FG8300 DOUBLE GLAZING TRACK
- C: FG8001 GLAZING BEAD
- D: FG8312 FLAT CLIP IN SECTION (WITH WELDED ANGLE)
- E: 44mm TIMBER DOOR LEAF



SAS International
31 Suttons Business Park,
London Road, Reading,
Berkshire, RG6 1AZ
Tel: 0118 929 0900
Fax: 0118 929 0908
Technical Helpline:
0118 929 0998
www.sasint.co.uk

SYSTEM 8000

105mm DOUBLE GLAZED
REDUCED HEAD DETAIL

SCALE @ A4
1:1
DRG NO
PS/8300/5205
ISSUED
INFORMATION

DATE
01/03/2012

DRAWN BY
TC
REV
01
CHECKED
KYE

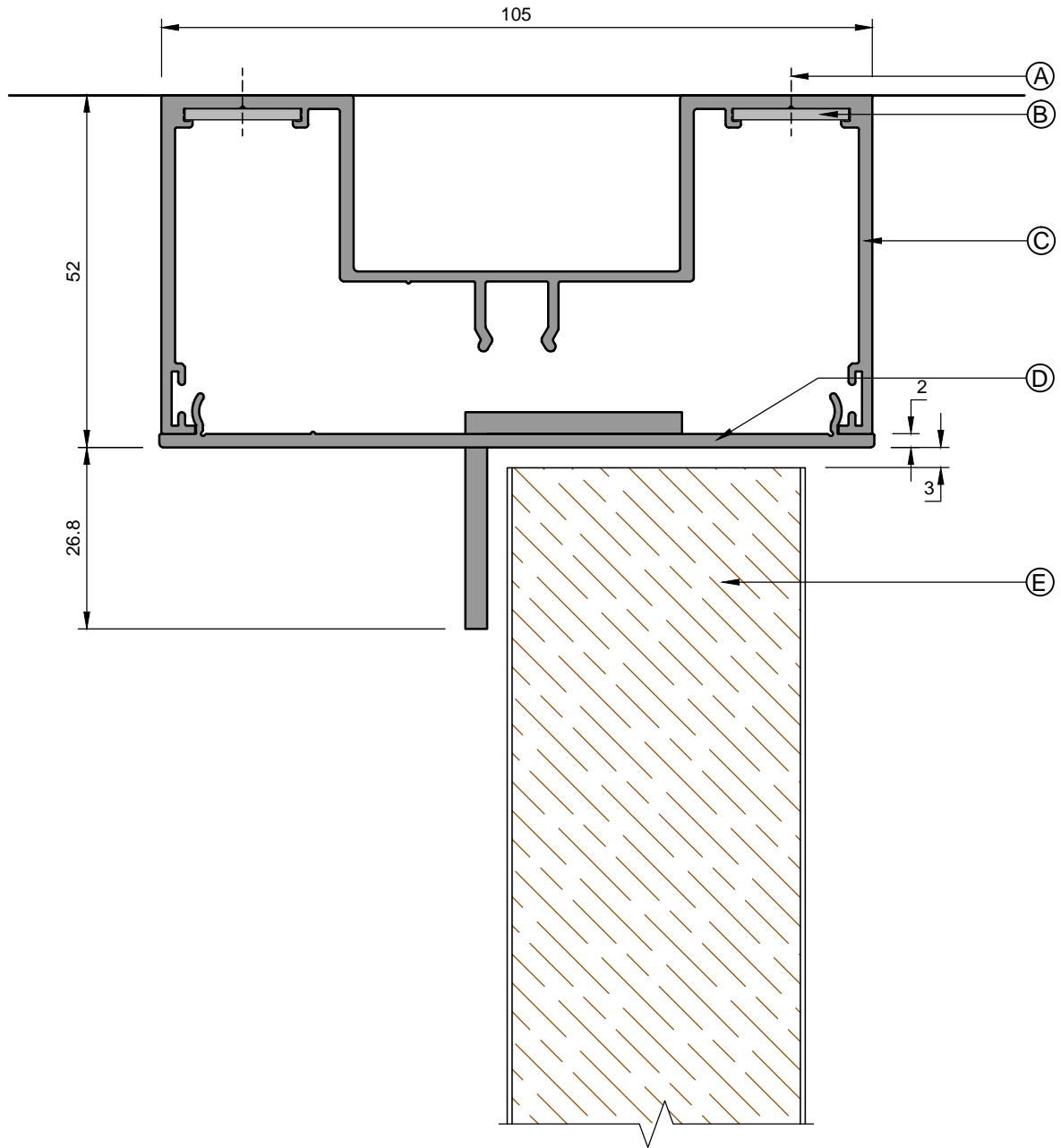

- A: SUITABLE FIXINGS
- B: 50 x 17mm SPLICE PLATE (STRAIGHT, 90° AND 135° AVAILABLE)
- C: FG8301 50mm HEAD TRACK
- D: FG8311 FLAT CLIP IN SECTION
- E: 32037 FLIPPER SEAL
- F: 44mm TIMBER DOOR LEAF

NON FIRE RATED

SEE FIRE RATED SERIES OF DRAWINGS



SAS International
 31 Suttons Business Park,
 London Road, Reading,
 Berkshire, RG6 1AZ
 Tel: 0118 929 0900
 Fax: 0118 929 0908
 Technical Helpline:
 0118 929 0998
 www.sasint.co.uk

SYSTEM 8000

105mm DOUBLE GLAZED
 REDUCED HEAD DETAIL

SCALE @ A4
 1:1
 DRG NO
 PS/8300/5206
 ISSUED
 INFORMATION

DATE
 01/03/2012

DRAWN BY
 TC
 REV
 01
 CHECKED
 KYE

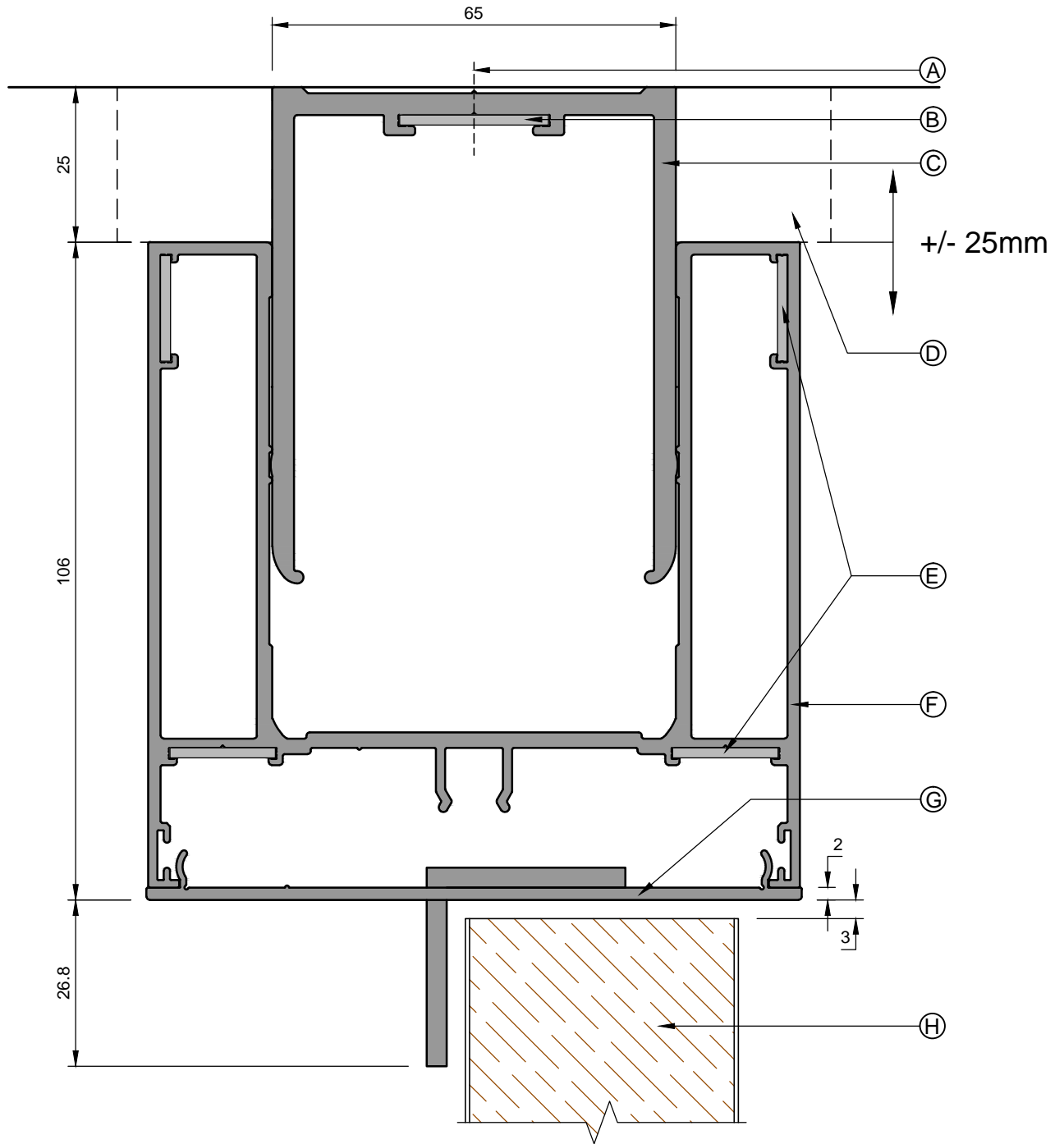

- A: SUITABLE FIXINGS
- B: 50 x 24mm SPLICE PLATE (STRAIGHT, 90° AND 135° AVAILABLE)
- C: DW1001 DOUBLE GLAZED DEFLECTION HEAD INNER CHANNEL
- D: 119476 25 x 25mm SETTING BLOCK
- E: 50 x 17mm SPLICE PLATE (STRAIGHT, 90° AND 135° AVAILABLE)
- F: FG8306 DOUBLE GLAZED DEFLECTION HEAD OUTER CHANNEL
- G: FG8311 FLAT CLIP IN SECTION
- H: 44mm TIMBER DOOR LEAF

NON FIRE RATED
SEE FIRE RATED SERIES
OF DRAWINGS



SAS International
31 Suttons Business Park,
London Road, Reading,
Berkshire, RG6 1AZ
Tel: 0118 929 0900
Fax: 0118 929 0908
Technical Helpline:
0118 929 0998
www.sasintl.co.uk

SYSTEM 8000

105mm DOUBLE GLAZED
REDUCED HEAD DETAIL

SCALE @ A4

1:1

DRG NO

PS/8300/5207

ISSUED

INFORMATION

DATE

01/03/2012

DRAWN BY

TC

REV

01

CHECKED

KYE

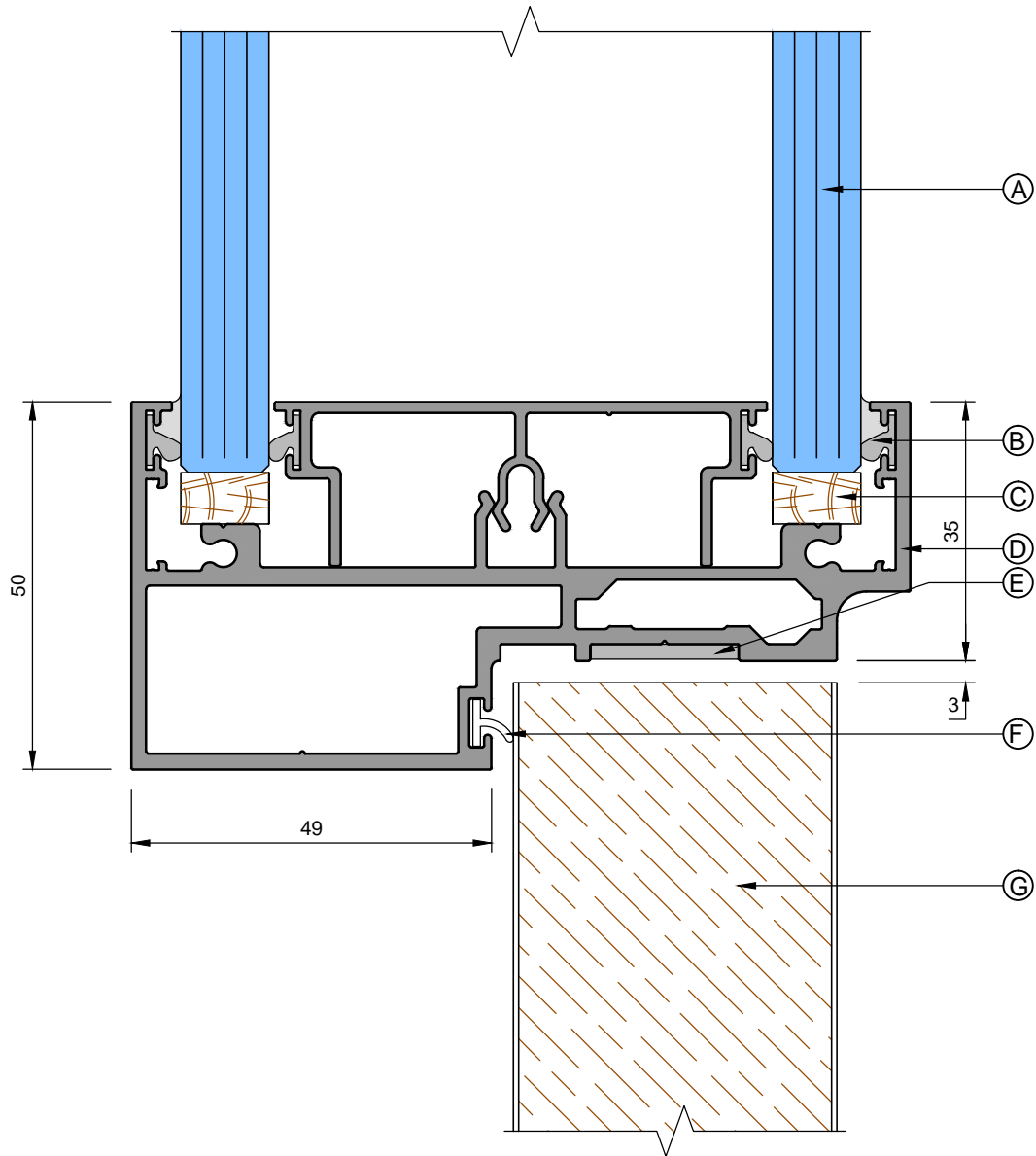

- A: 10/12mm GLASS
- B: 112217 Q-LON SEAL
- C: 111637 TIMBER PACKER FOR GLAZING ABOVE DOOR
- D: FG8307 DOUBLE GLAZED SQUARE DOOR FRAME
- E: PIS20X2 OPTIONAL COVER STRIP
- F: 32037 FLIPPER SEAL
- G: 44mm TIMBER DOOR LEAF

NON FIRE RATED
SEE FIRE RATED SERIES
OF DRAWINGS



SAS International
31 Suttons Business Park,
London Road, Reading,
Berkshire, RG6 1AZ
Tel: 0118 929 0900
Fax: 0118 929 0908
Technical Helpline:
0118 929 0998
www.sasint.co.uk

SYSTEM 8000

105mm DOUBLE GLAZED
DOORFRAME WITH GLASS ABOVE

SCALE @ A4
1:1
DRG NO
PS/8300/5208
ISSUED
INFORMATION

DATE
01/03/2012

DRAWN BY
TC
REV
01
CHECKED
KYE

PLEASE REFER TO
SUBSEQUENT
DRAWINGS FOR
OFFSET PIVOT TIMBER
DOOR JAMB OPTIONS

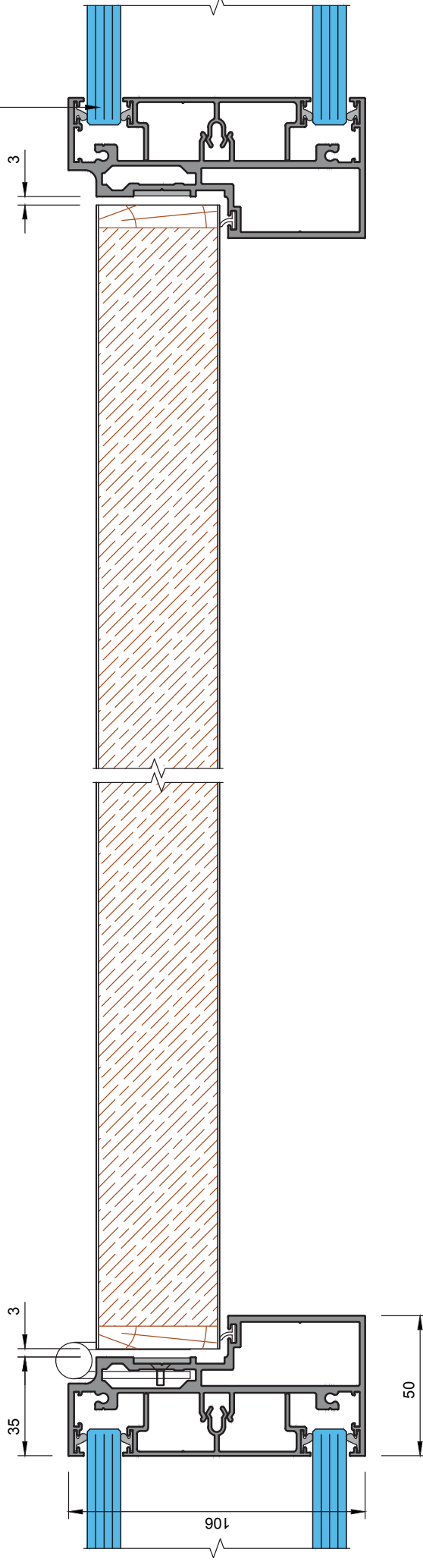

NON FIRE RATED
SEE FIRE RATED SERIES
OF DRAWINGS



SAS International
London Road, Reading, RG6 7AZ
Tel: 0118 922 0000
Fax: 0118 922 0008
Technical Hotline:
0118 922 0009
www.sasint.co.uk

SAS International claims proprietary rights in the information disclosed herein. This drawing is furnished in confidence on the express understanding that neither it nor any reproduction thereof will be disclosed to others or used for the purpose of manufacture or sale of any product without the express written consent of SAS International. It should be understood that any article or part either made in accordance with the attached drawing or copied from an article or part made in accordance with said drawing, without the express written consent of SAS International, will be an infringement of the copyright in the drawings in said drawing and therefore actionable by SAS International.
© 2010 SAS International

SYSTEM 8000
105mm DOUBLE GLAZED
FG8307 DOOR FRAME SECTION VIEW

SCALE @ A4 1:2
DRG NO PS/8300/5300
ISSUED INFORMATION

DATE 01/03/2012
DRAWN BY TC
REV 00
CHECKED KYE

PLEASE REFER TO
SUBSEQUENT DRAWINGS
FOR HINGED TIMBER
DOOR JAMB OPTIONS

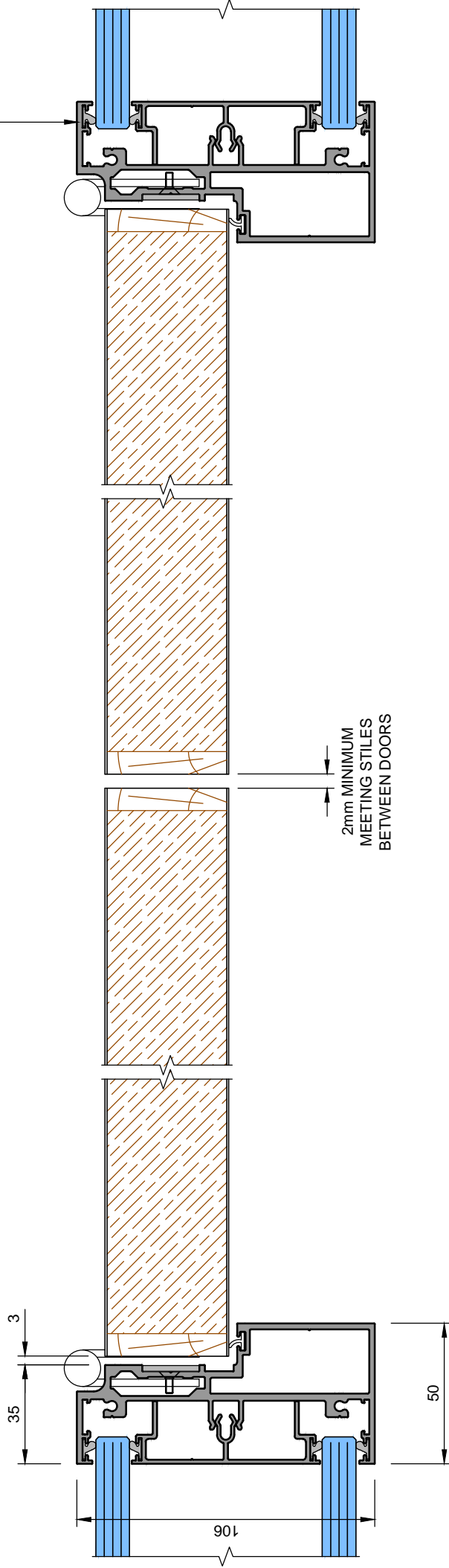

NON FIRE RATED
SEE FIRE RATED SERIES
OF DRAWINGS



SAS International
31 Salford Business Park,
London Road, Reading,
RG2 9AT, UK
Tel: 0118 929 0900
Fax: 0118 929 0909
Email: sales@sasint.co.uk
www.sasint.co.uk

SAS International claims proprietary rights in the information disclosed herein. This information is intended for use by the manufacturer of the product for the purpose of manufacturing or production thereof. It should be understood that any article or part either made in accordance with the information disclosed herein or used in the manufacture of such article or part without the express permission in writing of SAS International, will be an infringement of the Copyright which subsists in said drawing and therefore actionable by law.
© 2010 SAS International

SYSTEM 8000
105mm DOUBLE GLAZED
FG8205 DOOR FRAME SECTION VIEW

SCALE @ A4
1:2
DRG NO
PS/8300/5301
ISSUED
INFORMATION

DATE
01/03/2012

DRAWN BY
TC
REV
01
CHECKED
KYE

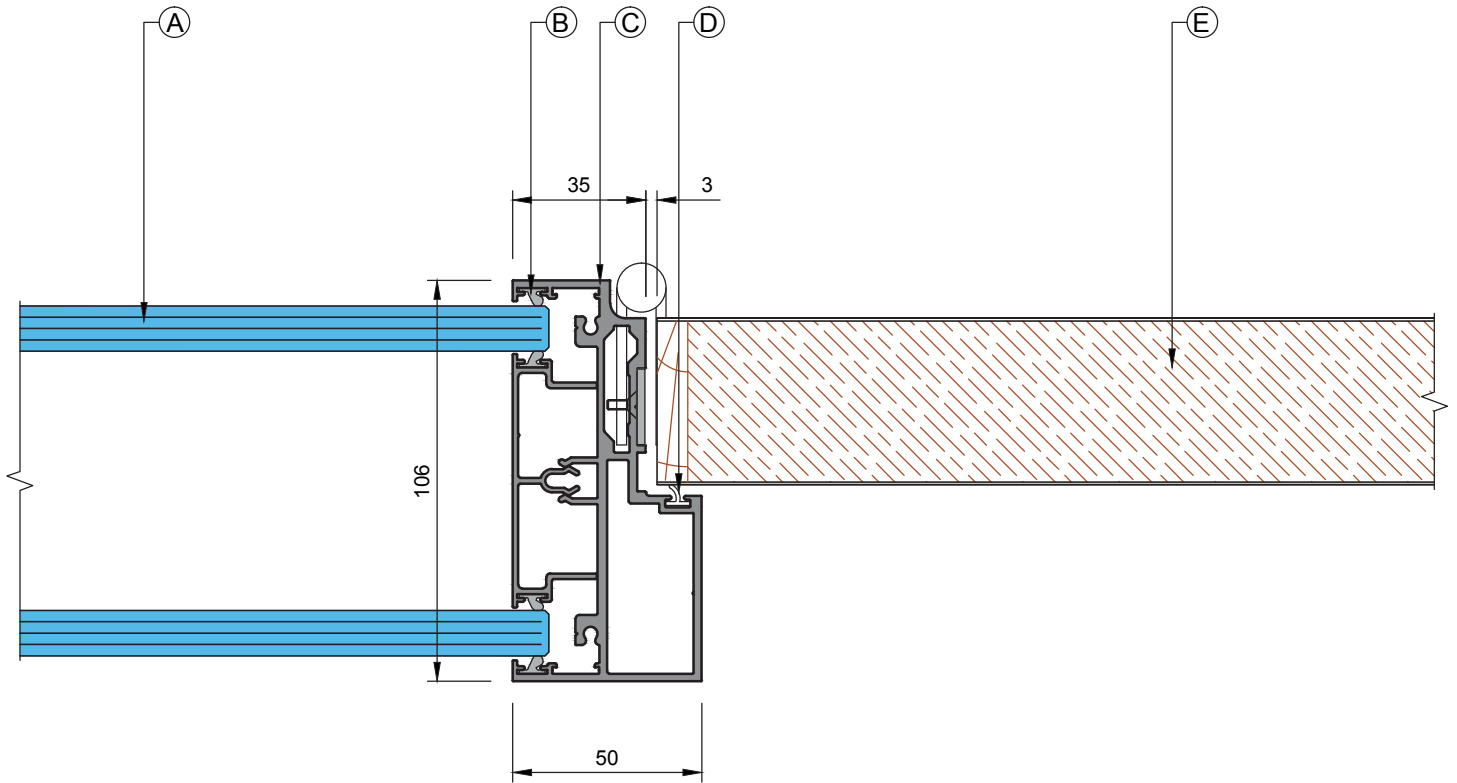

NON FIRE RATED
SEE FIRE RATED SERIES
OF DRAWINGS

A: 10/12mm GLASS (NOMINAL GLASS THICKNESS SHOWN)
B: 112217 Q-LON SEAL
C: FG8307 DOUBLE GLAZED SQUARE DOOR FRAME
D: 32037 FLIPPER SEAL
E: 44mm TIMBER DOOR LEAF



SAS International
31 Suttons Business Park,
London Road, Reading,
Berkshire, RG6 1AZ
Tel: 0118 929 0900
Fax: 0118 929 0908
Technical Helpline:
0118 929 0998
www.sasint.co.uk

SYSTEM 8000

105mm DOUBLE GLAZED
FG8307 DOOR FRAME JAMB

SCALE @ A4
1:2
DRG NO
PS/8300/5302
ISSUED
INFORMATION

DATE
01/03/2012

DRAWN BY
TC
REV
00
CHECKED
KYE

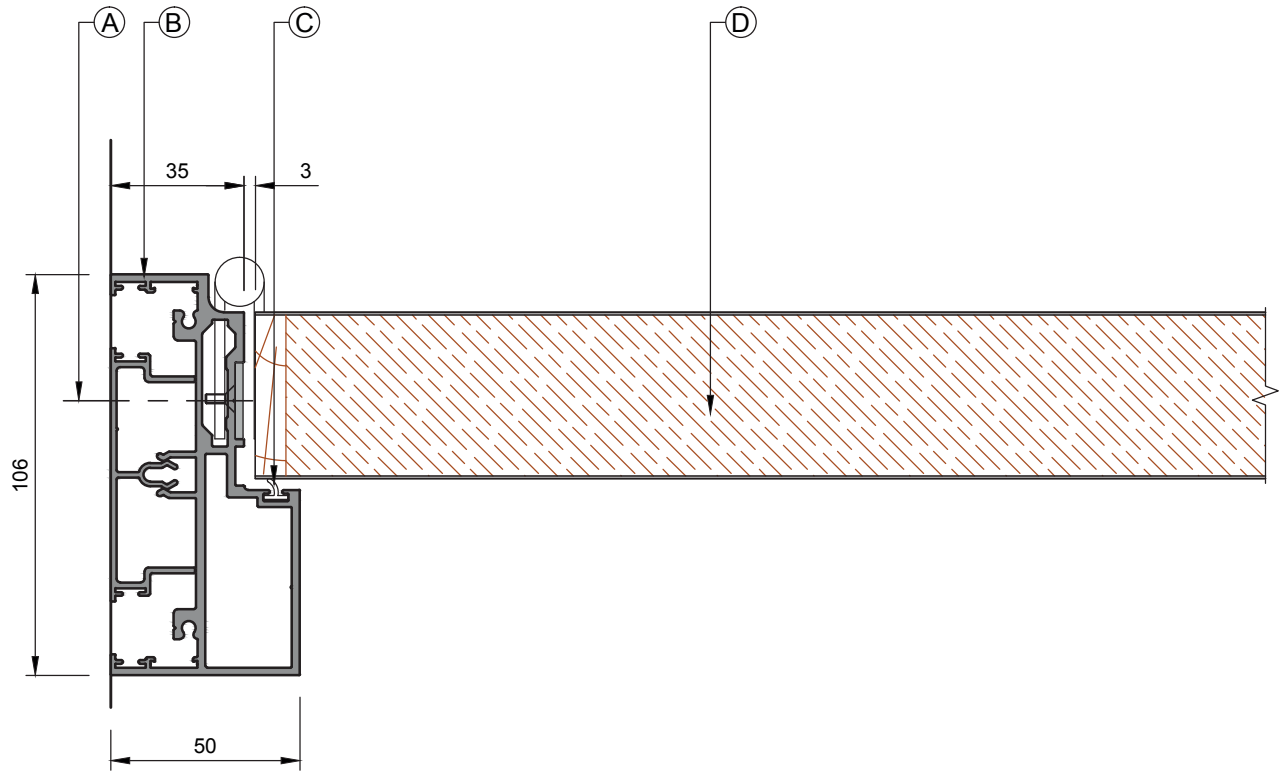

NON FIRE RATED
SEE FIRE RATED SERIES
OF DRAWINGS

A: SUITABLE FIXINGS
B: FG8307 DOUBLE GLAZED SQUARE DOOR FRAME
C: 32037 FLIPPER SEAL
D: 44mm TIMBER DOOR LEAF



SAS International
31 Suttons Business Park,
London Road, Reading,
Berkshire, RG6 1AZ
Tel: 0118 929 0900
Fax: 0118 929 0908
Technical Helpline:
0118 929 0998
www.sasint.co.uk

SYSTEM 8000

105mm DOUBLE GLAZED
FG8307 DOOR FRAME WALL ABUTMENT

SCALE @ A4
1:2
DRG NO
PS/8300/5303
ISSUED
INFORMATION

DATE
01/03/2012

DRAWN BY
TC
REV
00
CHECKED
KYE

drywall integration details

Drawing description	Drawing number
Inline Adaptor For 100mm Drywall (10/12mm Glass)	PS/8300/7000
Inline Adaptor For 120mm Drywall (10/12mm Glass).....	PS/8300/7001
Reveal Channel Head Detail (10/12mm Glass)	PS/8300/7004
Reveal Channel Wall Abutment (10/12mm Glass).....	PS/8300/7005

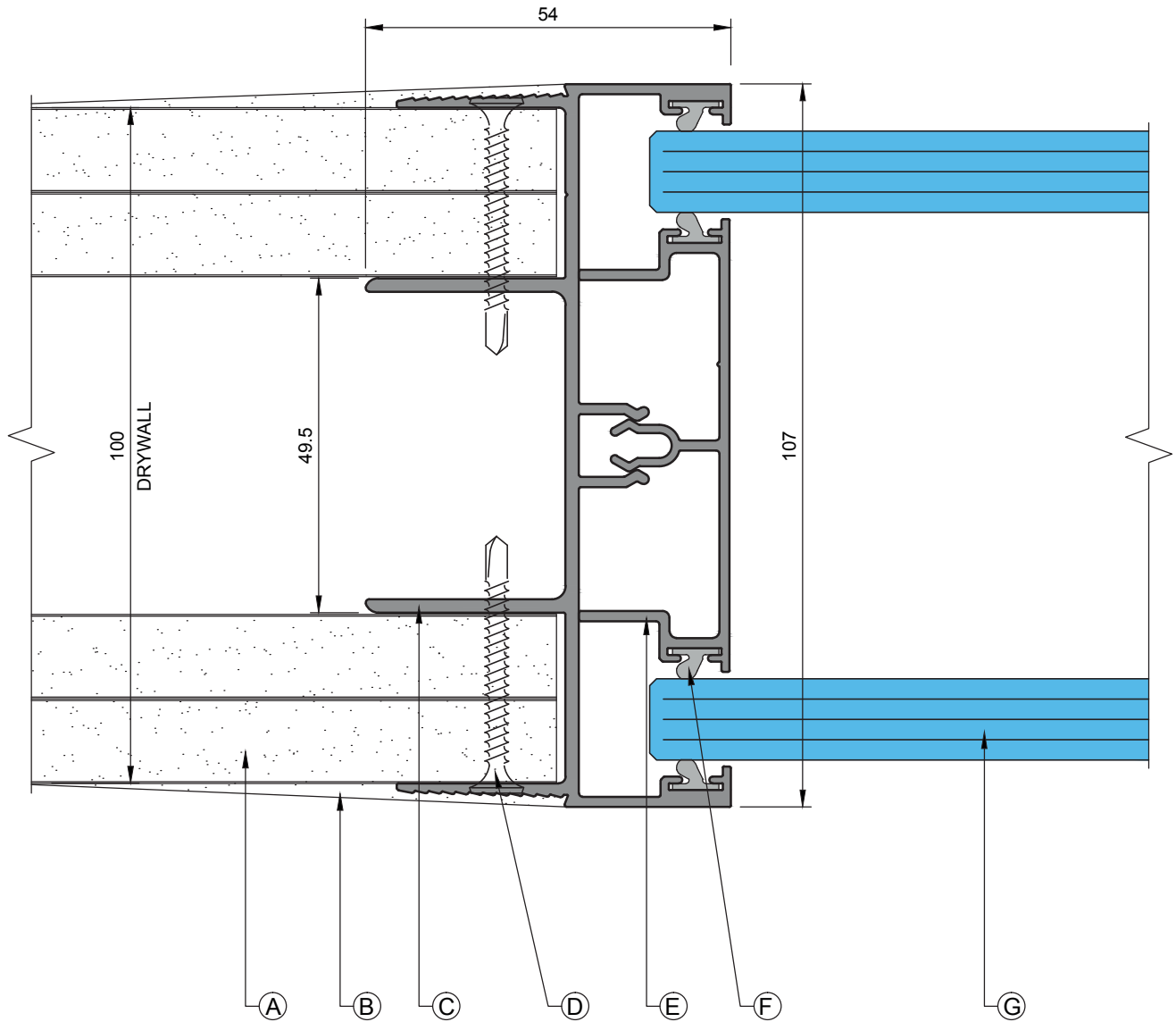

- A: 12.5mm PLASTERBOARD
- B: TAPED AND JOINTED
- C: FG8314 DOUBLE GLAZED ADAPTOR FOR 100mm DRYWALL
- D: 3.5 x 38mm JACK POINT DRY WALL SCREW @ 300mm CTRS
- E: FG8302 DOUBLE GLAZED 67mm INFILL
(FOR OTHER GLAZING INFILL OPTIONS PLEASE REFER TO DRAWING PS/8300/0901)
- F: 112217 Q-LON SEAL
- F: 10/12mm GLASS (NOMINAL GLASS THICKNESS NOTED)

NON FIRE RATED
SEE FIRE RATED SERIES
OF DRAWINGS



SAS International
31 Suttons Business Park,
London Road, Reading,
Berkshire, RG6 1AZ
Tel: 0118 929 0900
Fax: 0118 929 0908
Technical Helpline:
0118 929 0998
www.sasint.co.uk

SYSTEM 8000

105mm DOUBLE GLAZED
ADAPTOR FOR 100mm DRYWALL DETAIL

SCALE @ A4
1:1
DRG NO
PS/8300/7000
ISSUED
INFORMATION

DATE
01/03/2012

DRAWN BY
TC
REV
00
CHECKED
KYE

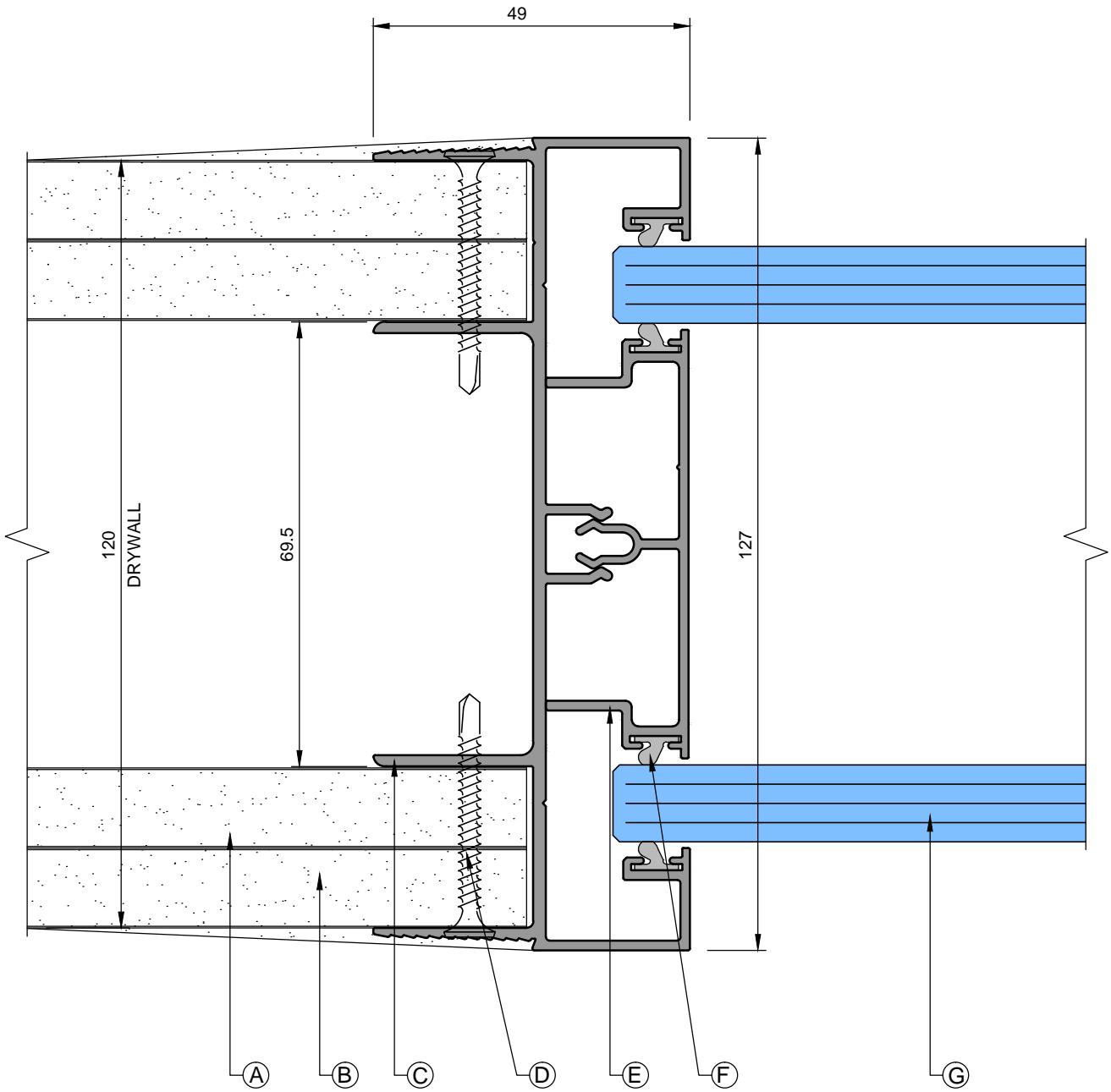

- A: 12.5mm PLASTERBOARD
- B: TAPED AND JOINTED
- C: FG8315 DOUBLE GLAZED ADAPTOR FOR 120mm DRYWALL
- D: 3.5 x 38mm JACK POINT DRYWALL SCREW @ 300mm CTRS
- E: FG8302 DOUBLE GLAZED 67mm INFILL
(FOR OTHER GLAZING INFILL OPTIONS PLEASE REFER TO DRAWING PS/8300/0901)
- F: 112217 Q-LON SEAL
- G: 10/12mm GLASS (NOMINAL GLASS THICKNESS NOTED)

NON FIRE RATED
SEE FIRE RATED SERIES
OF DRAWINGS



SAS International
31 Suttons Business Park,
London Road, Reading,
Berkshire, RG6 1AZ
Tel: 0118 929 0900
Fax: 0118 929 0908
Technical Helpline:
0118 929 0998
www.sasint.co.uk

SYSTEM 8000

105mm DOUBLE GLAZED
ADAPTOR FOR 120mm DRYWALL DETAIL

SCALE @ A4
1:1
DRG NO
PS/8300/7001
ISSUED
INFORMATION

DATE
01/03/2012

DRAWN BY
TC
REV
01
CHECKED
KYE

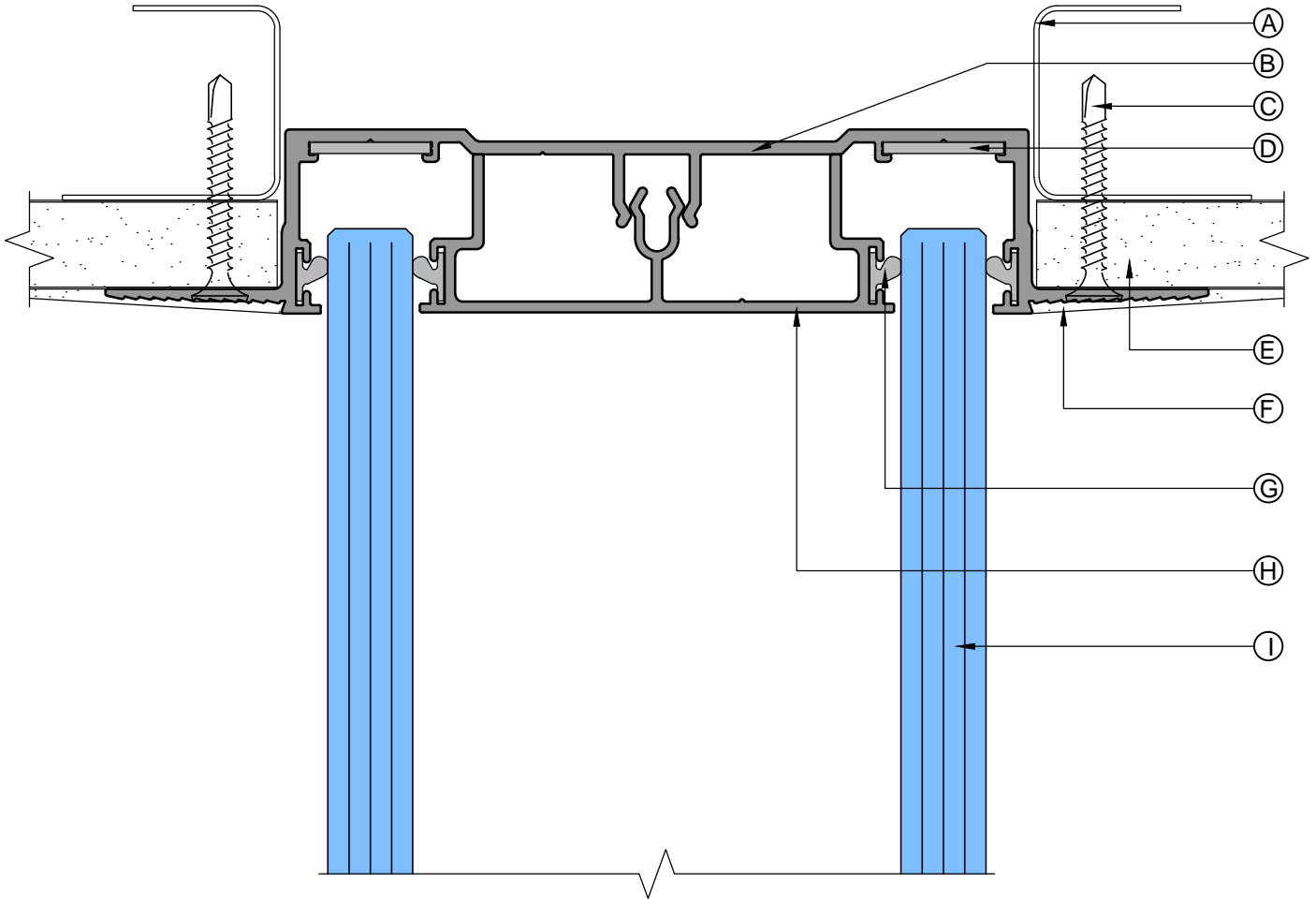

- A: EMAC6A PERIMETER
 B: FG8313 DOUBLE GLAZED REVEAL CHANNEL
 C: DRYWALL SCREW @ 300mm CTRS
 D: 110667 50 x 17mm FLAT SPLICE PLATE
 E: 12.5mm PLASTERBOARD
 F: TAPED AND JOINTED
 G: 112217 Q-LON SEAL
 H: FG8302 DOUBLE GLAZED 67mm INFILL
 (FOR OTHER GLAZING INFILL OPTIONS PLEASE REFER TO DRAWING PS/8300/0109)
 I: 10/12mm GLASS (NOMINAL GLASS THICKNESS NOTED)

NON FIRE RATED
 SEE FIRE RATED SERIES
 OF DRAWINGS



SAS International
 31 Suttons Business Park,
 London Road, Reading,
 Berkshire, RG6 1AZ
 Tel: 0118 929 0900
 Fax: 0118 929 0908
 Technical Helpline:
 0118 929 0998
 www.sasint.co.uk

SYSTEM 8000

105mm DOUBLE GLAZED
 REVEAL CHANNEL HEAD DETAIL

SCALE @ A4
 1:1
 DRG NO
 PS/8300/7004
 ISSUED
 INFORMATION

DATE
 01/03/2012

DRAWN BY
 TC
 REV
 01
 CHECKED
 KYE

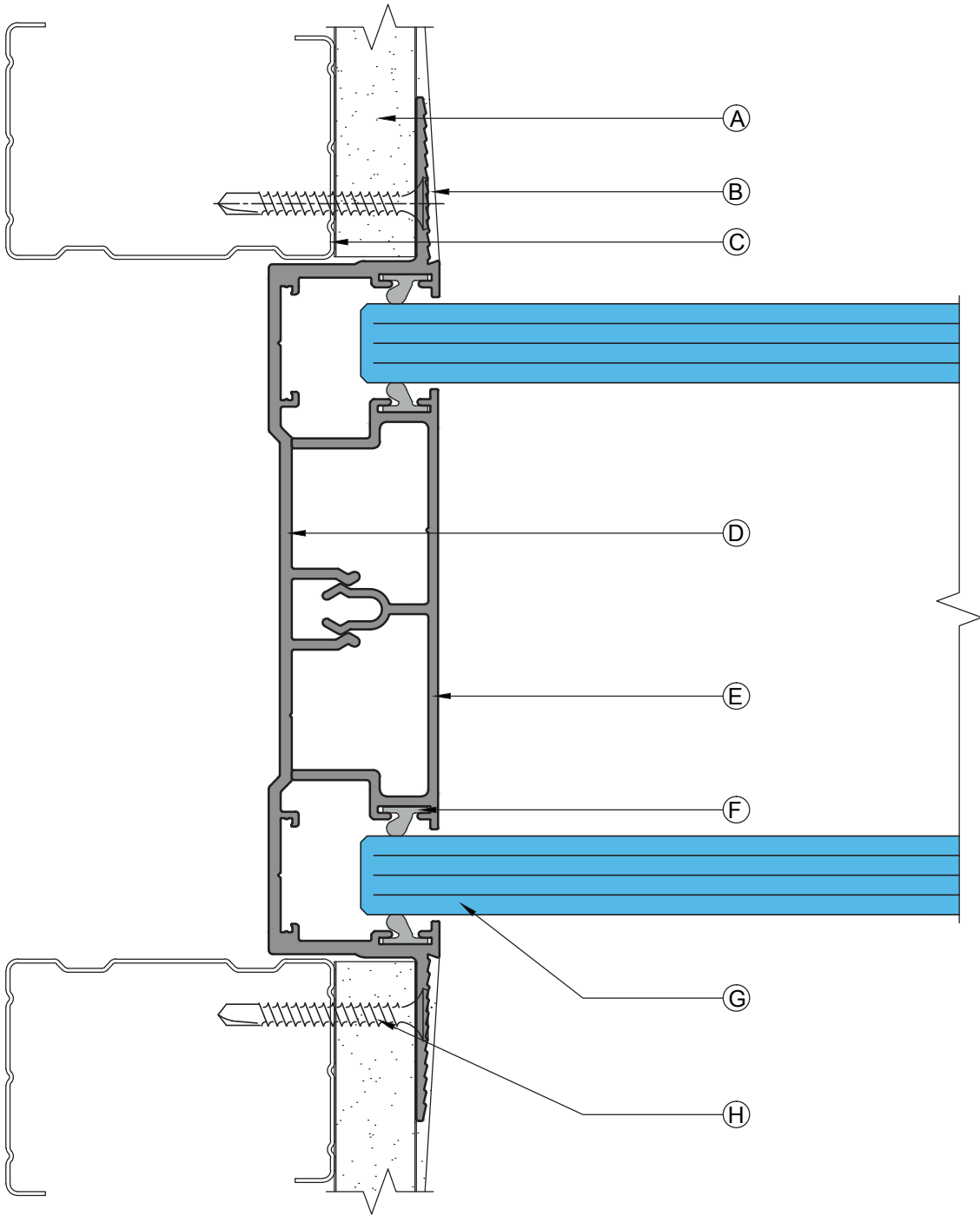

- A: 12.5mm PLASTERBOARD
- B: TAPED AND JOINTED
- C: STUD
- D: FG8313 DOUBLE GLAZED REVEAL CHANNEL
- E: FG8302 DOUBLE GLAZED 67mm INFILL
(FOR OTHER GLAZING INFILL OPTIONS PLEASE REFER TO DRAWING PS/8300/0901)
- F: 112217 Q-LON SEAL
- G: 10/12mm GLASS (NOMINAL GLASS THICKNESS NOTED)
- H: DRYWALL SCREW @ 300mm CTRS

NON FIRE RATED
SEE FIRE RATED SERIES
OF DRAWINGS



SAS International
31 Suttons Business Park,
London Road, Reading,
Berkshire, RG6 1AZ
Tel: 0118 929 0900
Fax: 0118 929 0908
Technical Helpline:
0118 929 0998
www.sasint.co.uk

SYSTEM 8000

105mm DOUBLE GLAZED
REVEAL CHANNEL WALL ABUTMENT

SCALE @ A4
1:1
DRG NO
PS/8300/7005
ISSUED
INFORMATION

DATE
01/03/2012

DRAWN BY
TC
REV
00
CHECKED
KYE

SAS International claims proprietary rights in the information disclosed herein. This drawing is furnished in confidence on the express understanding that neither it nor any reproduction thereof will be disclosed to others or used for the purpose of manufacture or procurement of the article or part shown hereon without the express consent in writing of SAS International. It should be understood that any article or part either made in accordance with the attached drawing or copied from an article or part made in accordance with said drawing, without the express permission in writing of SAS International, will be an infringement of the Copyright which subsists in said drawing and therefore actionable by law.
© 2010 SAS International

other system integration details

Drawing description

Drawing number

System 1000 / 105mm Double Glazed System 8000 (10/12mm Glass)	PS/8300/8000
System 1000 / 105mm Double Glazed System 8000 (10/12mm Glass)	PS/8300/8001

SYSTEM 1000 - DW1004 RUNS THROUGH THE GLAZING AND DRYWALL

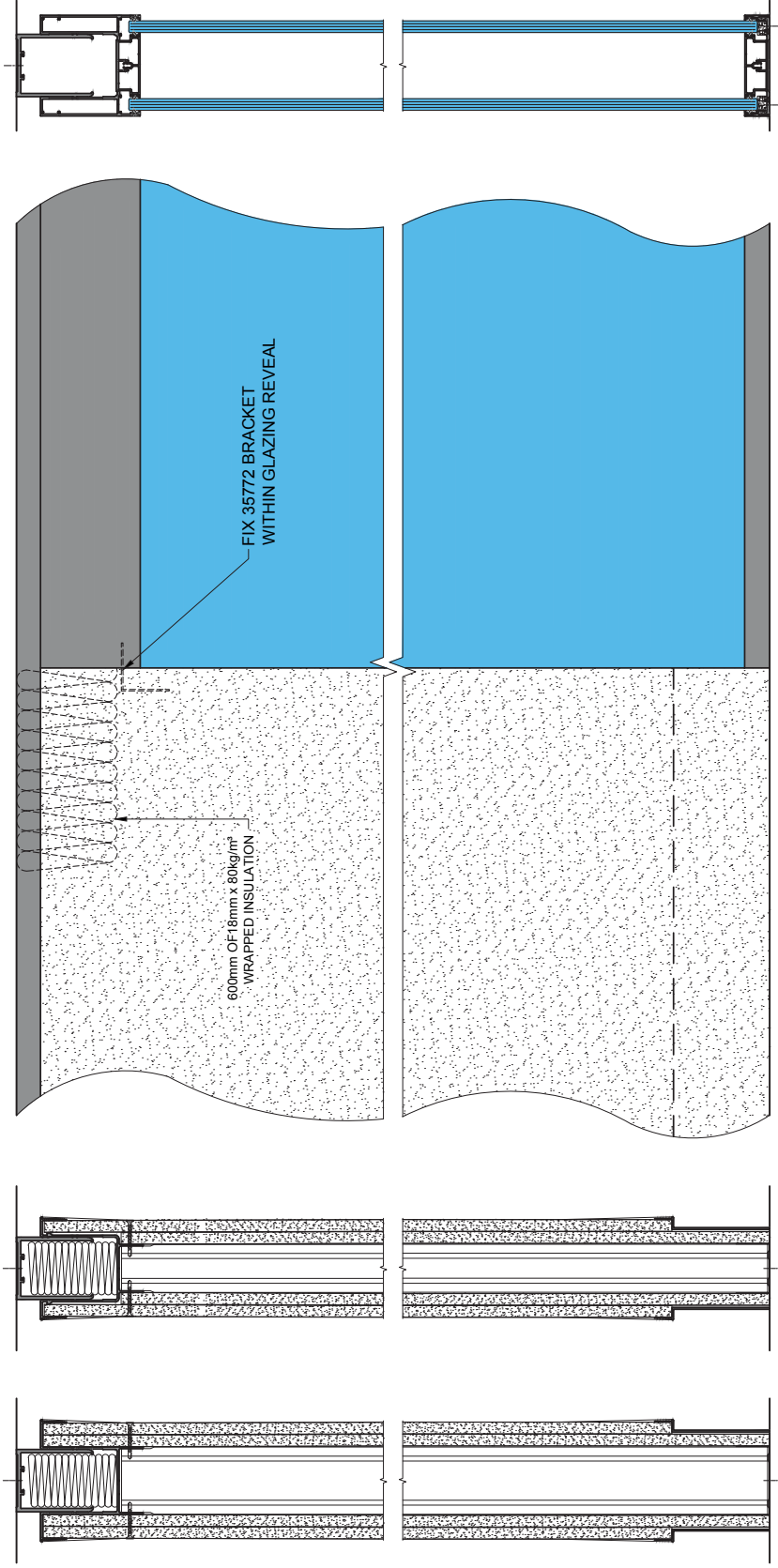

FG8314A FOR DEFLECTION HEAD MILLING
 FG8314AB FOR DEFLECTION HEAD AND
 100mm RECESSED SKIRTING MILLING
 TO SUIT TRU-SK 100

FG8315A FOR DEFLECTION HEAD MILLING
 FG8315AB FOR DEFLECTION HEAD AND
 100mm RECESSED SKIRTING MILLING
 TO SUIT TRU-SK 100

NOTE:

- ALL FEATHER EDGE DRYWALL SECTIONS REQUIRE FACTORY MILLING TO ACHIEVE THIS DETAIL
- MILLING IS OPTIONAL FOR RECESSED SKIRTING
- DRAWING SHOWS APPLICATION WHERE SYSTEM 1000 DW1004 RUNS THROUGH BOTH SYSTEM 8000 AND SYSTEM 1000.

SAS International
 London Road, Haverhill,
 Cambridgeshire, CB23 7BQ
 Tel: 01753 820000
 Fax: 01753 820008
 E-mail: sales@sas-international.com
 www.sas-int.com



SYSTEM 8000

105mm DOUBLE GLAZED +/- 25mm DEFLECTION HEAD
 TO SYSTEM 1000 INTEGRATION

SCALE @ A3
 5:1
 DRG NO
 PS/8300/8000
 ISSUED
 INFORMATION

DATE
 01/03/2012

DRAWN BY
 TC
 REV
 00
 CHECKED
 KYE

SAS International claims proprietary rights in the information disclosed herein. This drawing is furnished in confidence and is not to be used for any other purpose without the express consent in writing of SAS International. It should be understood that any article or part shown herein without the express consent in writing of SAS International, will be an infringement of the Copyright which subsists in said drawing and remains actionable by law.
 © 2010 SAS International

SYSTEM 1000 - DW1004

SYSTEM 1000 - DW1004

2

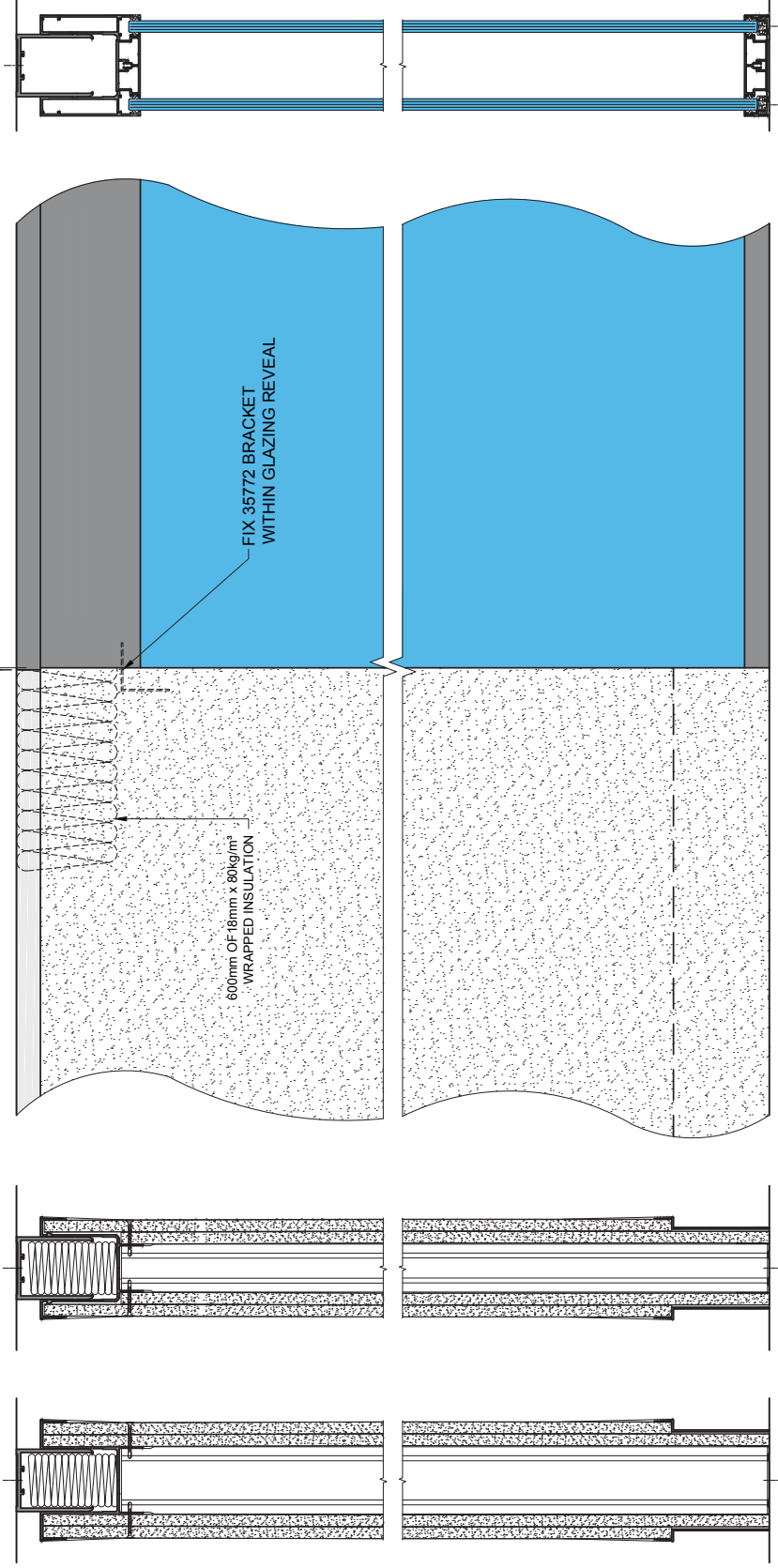

FIX 35772 BRACKET WITHIN GLAZING REVEAL

600mm OF 18mm x 80kg/m³ WRAPPED INSULATION

FG8314A FOR DEFLECTION HEAD MILLING
FG8314AB FOR DEFLECTION HEAD AND 100mm RECESSED SKIRTING MILLING TO SUIT TRU-SK 100

FG8315A FOR DEFLECTION HEAD MILLING
FG8315AB FOR DEFLECTION HEAD AND 100mm RECESSED SKIRTING MILLING TO SUIT TRU-SK 100

NOTE:

- ALL FEATHER EDGE DRYWALL SECTIONS REQUIRE FACTORY MILLING TO ACHIEVE THIS DETAIL
- MILLING IS OPTIONAL FOR RECESSED SKIRTING
- DRAWING SHOWS APPLICATION WHERE SYSTEM 1000 DW1004 RUNS THROUGH BOTH SYSTEM 8000 AND SYSTEM 1000. TWO SEPERATE SECTIONS ARE DIFFERENT COLOURS.

DRAWN BY TC
REV 00
CHECKED KYE

DATE 01/03/2012

SCALE @ A3 5:1
DRG NO PS/8300/8001
ISSUED INFORMATION

SYSTEM 8000

105mm DOUBLE GLAZED +/- 25mm DEFLECTION HEAD TO SYSTEM 1000 INTEGRATION

SAS International claims proprietary rights in the information disclosed hereon. This drawing is furnished in confidence and is not to be reproduced, stored in a retrieval system, or transmitted in any form or by any means, electronic, mechanical, photocopying, recording, or otherwise, without the express consent in writing of SAS International. It should be understood that any article or part either made in accordance with the attached drawing or copied therefrom, in whole or in part, without the express consent in writing of SAS International, will be an infringement of the Copyright which subsists in said drawing and therefore actionable by law.
© 2010 SAS International

SAS International
London Road, Huddersfield,
West Yorkshire, HD1 1JY
Tel: 01484 520000
Fax: 01484 520008
Email: sales@sas-intl.com
www.sas-intl.com



door frame and glazing infill options

Drawing description

Drawing number

105mm Double Glazed Door Frame Options	PS/8300/9000
105mm Double Glazed Infill Options	PS/8300/9001

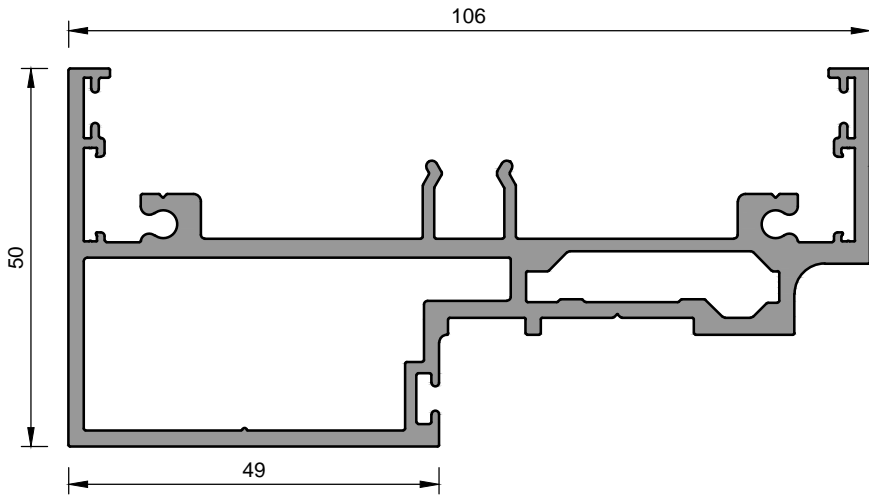

FG8307 - 105mm DOUBLE GLAZED SQUARE DOOR FRAME

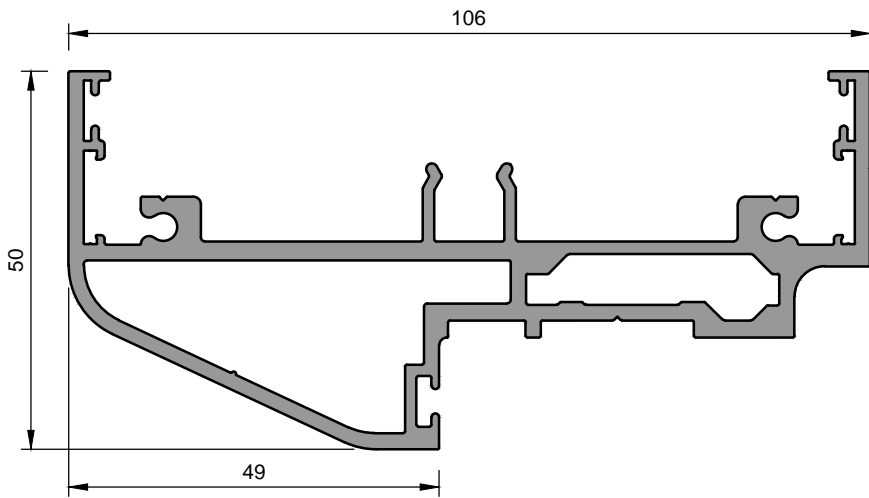

FG8308 - 105mm DOUBLE GLAZED CHAMFERED DOOR FRAME

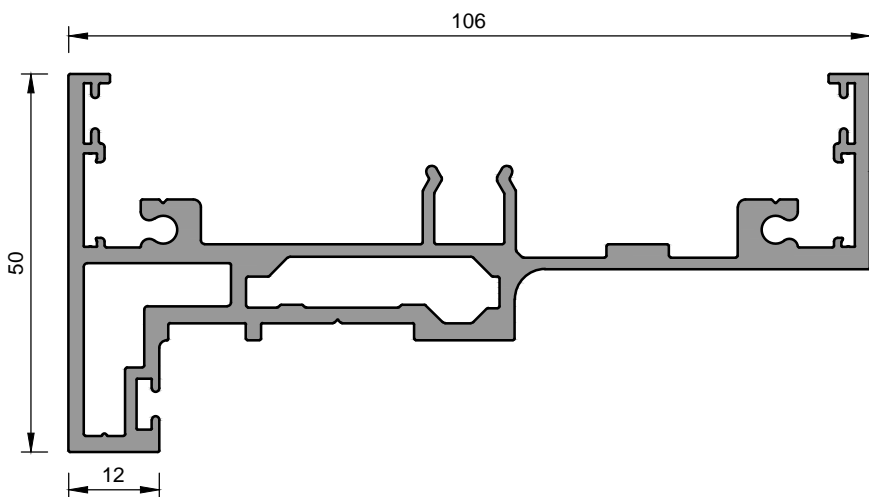

FG8309 - 105mm DOUBLE GLAZED DOOR FRAME (12mm DOOR STOP)

NOTE:
FG8309 IS NOT SUITABLE FOR
USE WITH OFFSET PIVOTS



SAS International
31 Suttons Business Park,
London Road, Reading,
Berkshire, RG6 1AZ
Tel: 0118 929 0900
Fax: 0118 929 0908
Technical Helpline:
0118 929 0998
www.sasint.co.uk

SYSTEM 8000

105mm DOUBLE GLAZED
DOOR FRAME OPTIONS

SCALE @ A4
1:1
DRG NO
PS/8300/9000
ISSUED
INFORMATION

DATE
01/03/2012

DRAWN BY
TC
REV
01
CHECKED
KYE

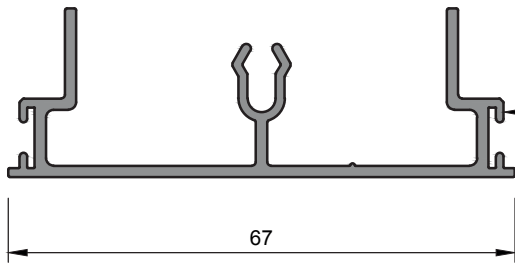

FG8302 - 105mm DOUBLE GLAZED
67mm INFILL TO SUIT 10/12mm +
10/12mm GLASS

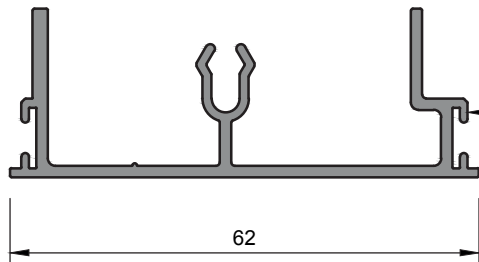

FG8303 - 105mm DOUBLE GLAZED
62mm INFILL TO SUIT 10/12mm +
15/17mm GLASS

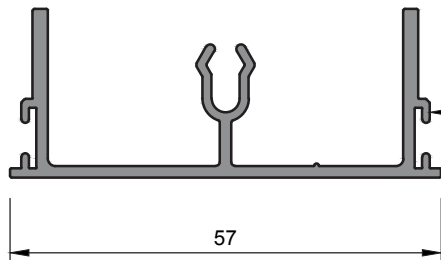

FG8304 - 105mm DOUBLE GLAZED
57mm INFILL TO SUIT 15/17mm +
15/17mm GLASS

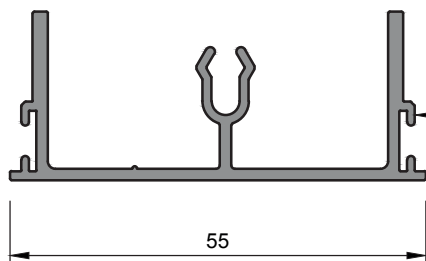

FG8305 - 105mm DOUBLE GLAZED
55mm INFILL TO SUIT 15/17mm +
19/22mm GLASS



SAS International
31 Suttons Business Park,
London Road, Reading,
Berkshire, RG6 1AZ
Tel: 0118 929 0900
Fax: 0118 929 0908
Technical Helpline:
0118 929 0998
www.sasint.co.uk

SYSTEM 8000

105mm DOUBLE GLAZED
INFILL OPTIONS

SCALE @ A4
1:1
DRG NO
PS/8300/9001
ISSUED
INFORMATION

DATE
01/03/2012

DRAWN BY
TC
REV
00
CHECKED
KYE

